

# Horn/Strobe/Speaker Damage Stoppers®

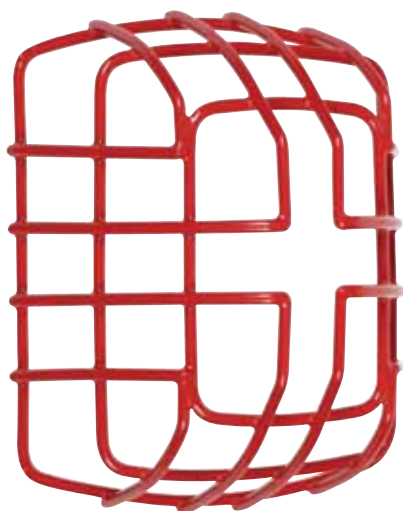

STI-9705-R



STI-9711



STI-9720

## PRODUCT OVERVIEW

Here are excellent ways to protect strobe units against both vandalism and accidental damage. Constructed of tough, 9-gauge steel wire coated with corrosion resistant red or white polyester, these guards can take hard knocks in stride. STI-9705, STI-9708, STI-9711 and STI-9714 wire guards provide maximum protection for System Sensor SpectrAlert® Advance series strobe notification appliances.

## BACKED BY A THREE YEAR GUARANTEE

As all STI protective covers, these guards are backed by a three year guarantee against breakage in normal use. Installation and servicing is easy with all screws and anchors provided. This Stopper is highly recommended for areas where abuse is severe or it is imperative that strobe units continue to operate. STI-9717 and STI-9720 fit over System Sensor notification appliances SP2R1224MC and SP2W1224MC.

## FEATURES

- Offers protection against vandalism and accidental damage.
- Constructed of tough 9-gauge steel wire.
- Installation is fast and simple with screws and anchors provided.
- Simple removal for maintenance.
- Coated with corrosion resistant polyester.
- STI-9705, STI-9708, STI-9711 and STI-9714 protect SpectrAlert® strobe units.
- STI-9717 and STI-9720 fit over System Sensor notification appliances SP2R1224MC and SP2W1224MC.
- Three year guarantee against breakage in normal use.

# Horn/Strobe/Speaker Damage Stoppers®

Dimensions and Technical Information

## MODELS AVAILABLE

<b>STI-9705</b>	Damage Stopper, Flush Mount - White
<b>STI-9705-R</b>	Damage Stopper, Flush Mount - Red
<b>STI-9708</b>	Damage Stopper, Surface Mount - White
<b>STI-9708-R</b>	Damage Stopper, Surface Mount - Red
<b>STI-9711</b>	Damage Stopper, Flush Mount - White
<b>STI-9714</b>	Damage Stopper, Surface Mount - White
<b>STI-9717</b>	Speaker/Strobe Damage Stopper - Flush Mount (not UL Listed)
<b>STI-9720</b>	Speaker/Strobe Damage Stopper - Surface Mount (not UL Listed)

MODEL	HEIGHT	WIDTH	DEPTH
STI-9705			
STI-9705-R	7.40 in. (188mm)	6.15 in. (156mm)	3.39 in. (84mm)
STI-9708			
STI-9708-R	7.49 in. (190mm)	6.74 in. (171mm)	6.09 in. (155mm)
STI-9711	8.26 in. (210mm)	8.26 in. (210mm)	3.54 in. (90mm)
STI-9714	8.55 in. (217mm)	8.55 in. (217mm)	6.23 in. (158mm)
STI-9717	6.1 in. (155mm)	9.3 in. (238mm)	2.4 in. (61mm)
STI-9720	6.1 in. (155mm)	9.3 in. (238mm)	4.9 in. (125mm)

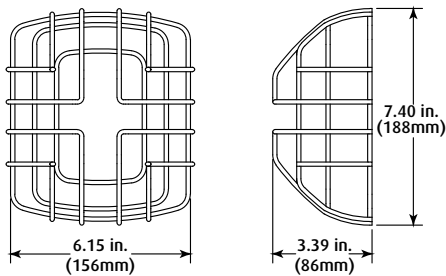

STI-9705

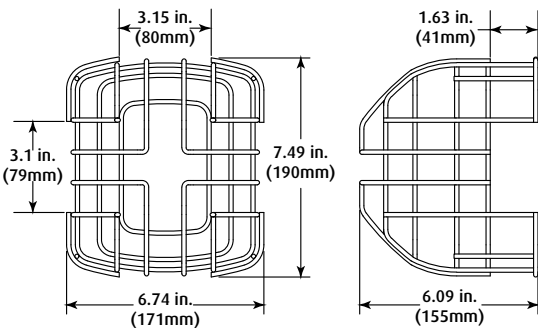

STI-9708

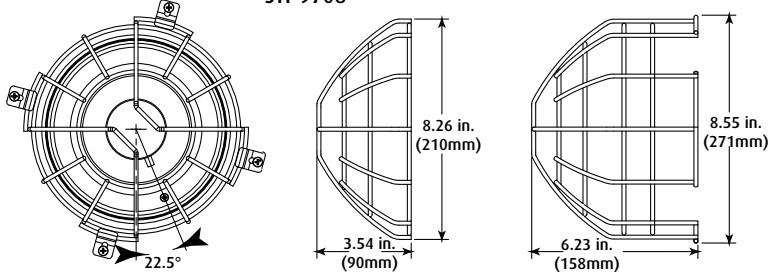

STI-9711

STI-9714

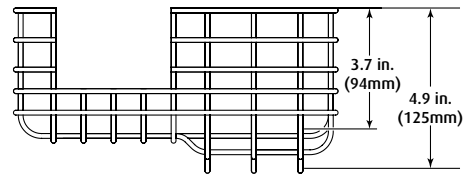

STI-9720  
TOP VIEW

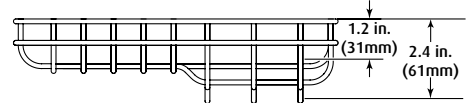

STI-9717  
TOP VIEW

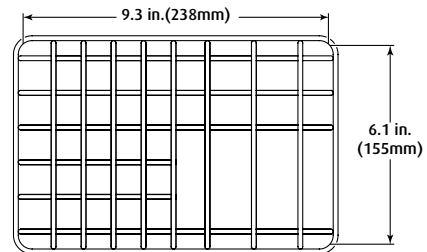

STI-9717 and STI-9720  
FRONT VIEW

## APPROVALS & WARRANTY

### TESTING

STI-9705, STI-9708, STI-9711 and STI-9714 have been tested and approved or listed by:

· Underwriter Laboratories and Canadian UL File S7025

### WARRANTY

Three year guarantee against breakage in normal use.

### Light De-Rating Factor

#### STI-9705 and STI-9708

System Sensor (SR, SW, SW-ALERT, SW-CLR-ALERT, SRK, SWK, P2R, P2W, P4R, P4W, CHSR, CHSW, P2RK, P2WK, P4RK, P4WK, SPSR, SPSR-SP, SPSR-PG, SPSW, SPSW-CLR-ALERT, SPSW-SP, SPSW-PG, SPSRV, SPSRV-SP, SPSRV-PG, SPSWV, SPSWV-SP and SPSWV-PG, SPSWK, SPSRK, SPSW-ALERT)

Light Loss  
%

13%

System Sensor (SRH, SWH, SRHK, SWH-ALERT, SWHK, P2RH, P2WH, P4RH, P2RHK, P2WHK, P2RHK-120, SPSRH, SPSRH-SP, SPSRH-PG, SPSWH, SPSWH-SP and SPSWH-PG, SPSRHK)

0%

#### STI-9711 and STI-9714

System Sensor (SCR, SCW, SCRK, SCWK, SCW-CLR-ALERT, PC2R, PC2W, PC4R, PC4W, PC2RK, PC2WK, PC4WK, SPSCWV, SPSCR, SPSCR-SP, SPSCR-PG, SPSCW, SPSCW-SP, SPSCW-PG, SPSCRV, SPSCRV-PG, SPSCWV, SPSCWV-SP and SPSCWV-PG, SPSCWK, SPSCW-CLR-ALERT)

0%

System Sensor (SCRH, SCWH, SCRHK, SCWHK, PC2RH, PC2WH, PC4RH, PC2RHK, PC2WHK, PC4WHK, SPSCWHV, SPSCRH, SPSCRH-SP, SPSCRH-PG, SPSCWH, SPSCWH-SP, SPSCWH-PG, SPSCRVH, SPSCRVH-SP, SPSCRVH-PG, SPSCWHV-SP, SPSCWHV-PG, SPSCWHK)

0%



**Safety Technology International, Inc.**

2306 Airport Road  
Waterford, Michigan  
48327, USA

Tel: 248-673-9898  
Fax: 248-673-1246  
Tollfree: 800-888-4784  
info@sti-usa.com  
www.sti-usa.com

Unit 49G Pipers Road  
Park Farm Industrial Estate  
Redditch, Worcestershire  
B98 0HU England

Tel: 44 (0) 1527 520 999  
Fax: 44 (0) 1527 501 999  
Free: 0800 085 1678 (UK)  
www.sti-europe.com