

SBTL5200 Series

SBTL5200 Swing Barrier Turnstile for an additional lane

SBTL5211 Swing Barrier Turnstile for an additional lane
(w/ controller and RFID reader)

SBTL5222 Swing Barrier Turnstile for an additional lane
(w/ controller and fingerprint & RFID reader)

The ZKTeco USA SBTL5200 swing barrier turnstile for an additional lane is an elegant cost-effective entrance control system designed for high-traffic volume. The SBTL5200 series should work together with SBTL5000 series to build multiple lanes.

The SBTL5200 is a swing barrier turnstile for an additional lane series designed for smooth and silent operation and draws very little power. It's made of stainless steel which makes SBTL5200 highly durable.

SBTL5200 barriers are normally held in a locked position, thus denying access to the secured side. Upon SBTL5200's reader (RFID and/or fingerprint) positively recognizing a user's valid access card or fingerprint, its barriers swing automatically, thus allowing users passage to the secured side.

SBTL5200 provides both security and convenient space, all in a very durable and elegant compact design.

Features

Reliability

- SUS304 stainless steel case ensure long-lasting durability.
- High quality electrical components Safety Features.
- All smooth finish. No exposed screws.
- Ergonomic design makes card and fingerprint authentication fast & simple for users.

Built-in Reader Integration

- SBTL5200 series already integrated with customers' preference for either card or fingerprint access control reader which greatly reduces installation time & expenses.
- SBTL5200 series and associated access control readers have passed the factory test before shipment.
- ZKTeco provides the plug & play device with the lowest price in the whole industry.

Simplification

- Simplify structure and connection, easy to maintain.
- Control board with LCD screen, easy to operate.

Specifications

Power requirements	AC 100 ~ 120V/200 ~ 240V, 50/60Hz	
Working temperature	-28°C ~ 60°C	
Working humidity	20%-95% (Non-condensing)	
Working environment	Indoor	
Speed of throughput	RFID	Maximum 30/ minute
	Fingerprint	Maximum 25/ minute
Lane width(mm)	650	
Footprint(mm*mm)	1400*780	
Dimensions(mm)	L=1400, W=180, H=1000	
Dimension with packing(mm)	L=1500, W=260, H=1100	
Net weight(kg)	72	
Weight with packing(kg)	87	
Cabinet material	SUS304 Stainless Steel	
Lid material	Tempered Glass	
Barrier material	Tempered Glass	
Barrier movement	Swing	
Emergency mode	Y	
Security level	Medium	
MCBF	2 million	

Dimensions (mm)

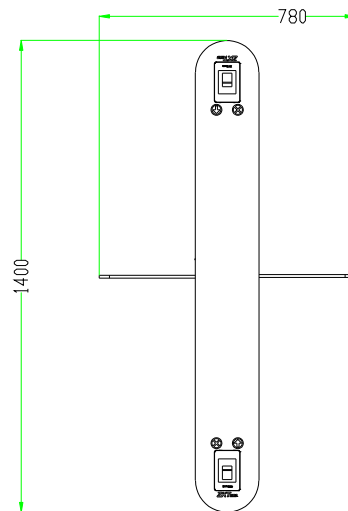
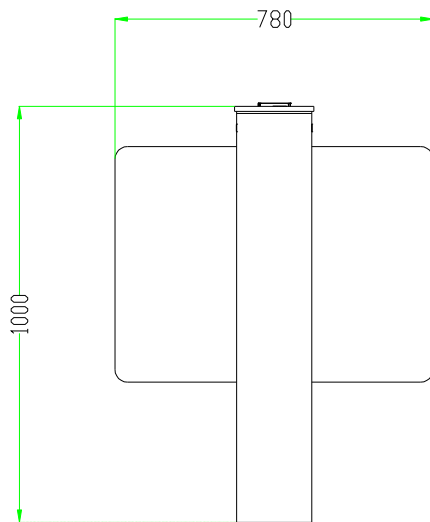

ZKTeco USA

1600 Union Hill Road Alpharetta, GA 30092
 Phone: (862) 505-2101 • Fax: (862) 204-5906 • sales@zktecousa.com • www.zktecousa.com

© Copyright 2014. ZKTeco Inc. ZKTeco Logo and ZKAccess Logo are registered trademarks of ZKTeco or a related company. All other product and company names mentioned are used for identification purposes only and may be the trademarks of their respective owners. All specifications are subject to change without notice. All rights reserved.

