



333 Bayview Avenue
Amityville, New York 11701
For Sales and Repairs, (800) 645-9445
For Technical Service, (800) 645-9440
Publicly traded on NASDAQ Symbol: NSSC

© NAPCO 2010

NAPCO GEMINI C-SERIES GEMC-BM BURGLARY MODULE INSTALLATION INSTRUCTIONS

WI1701 06/10

OVERVIEW

A Burg Module is required for UL Combination Burglary and Fire and Burglary-only installations to provide a separate, isolated bus for burglary keypad(s) that are required for annunciation and other burglary/access control peripheral devices. For UL Commercial installations, the unit is to be housed in an attack resistant enclosure such as the GEMC-HSKIT1425 or GEMC-HSKIT1416 employed with the GEMC-TAMPERKIT. See WI1653 for GEMC Series installation instructions.

Two Burg Module Options

There are two types of Burg Modules. Both provide the same isolated Burglary and access control features, however, the voltage and current ratings for each are different, requiring different power calculations depending on system back-up battery configurations. The two types of Burg Modules are as follows:

- **GEMC-BM** Burg Module without power supply; utilizes the Fire system batteries (see WI1701)
- **GEMC-BM/PS** Burg Module with 24V to 12V converter and back-up 12V, 8AH max battery charger with monitor circuit

SPECIFICATIONS

Electrical Ratings

Input Power: 12V Regulated, 25mA standby plus total combined standby and alarm current. Must reduce GEMC-XXXMB total 12V standby current by GEMC-MB total standby current plus 25mA.

Note: GEMC-BM total standby and alarm current plus GEMC-XXXMB total 12V standby and 12V alarm current must not exceed 2.5A.

Output Power:

Burg Bell Power: 12VDC Regulated, 2A maximum.

AUX Power: 12VDC Regulated, 750mA maximum.

Burg Bus Power ("Remote Bus Power"): 12V Regulated, 750mA maximum.

PGM1: Active low, 10.6 - 12VDC @ 150mA.

PGM2: Active low, 10.6 - 12VDC @ 150mA (For UL Commercial installations)

Aux Relay: Wet 12V Regulated @ 750mA maximum (subtract from AUX Power); may be set to a dry form "c" relay contact upon removing the jumper "R"; output rated 30VDC, 3A (Resistive Load)

Total Combined Standby Current (Auxiliary power + Burg Bus power + Aux Relay power +25mA standby current): 750mA.

Total Combined Standby and Alarm Current (Auxiliary power + Burg Bus power + Aux Relay power + Bell power): 2.5A.

INSTALLATION

The GEMC-BM is pre-assembled at the factory with two support bars as shown in the image below:

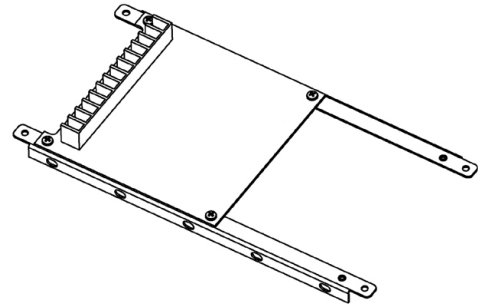

PRE-ASSEMBLED GEMC-BM BURG MODULE

1. Place the Burglary Module PCB on top of the Support Bars and secure using the 6-32 screws (item #6).

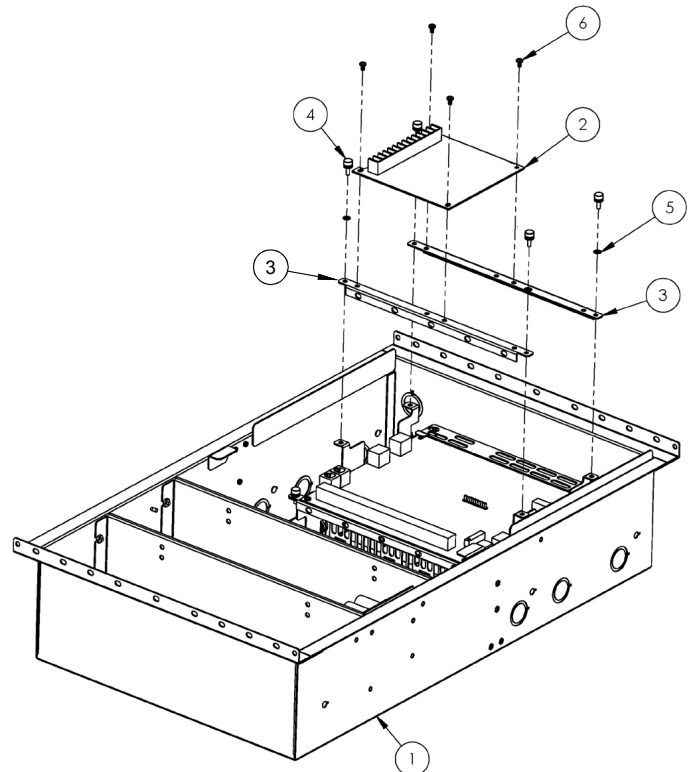

EXPLODED VIEW OF GEMC-BM BURG MODULE.
SEE TABLE BELOW FOR NUMBER DESCRIPTIONS

Item	Part Number	Description	QTY
1	HW1688	Enclosure base	1
2	PCB Burg	Burg PCB	1
3	HW1490	Support Bar	2
4	SC628	Thumbscrew	4
5	WA107	#6 External Tooth Star Washer	4
6	SC270	Screw 6-32 x .25 with washer (sems)	4

2. **Align the combination HW1490 Support Bars** and Burglary Module PCB with the holes located in HW1492 Right Side Plate and the HW1491 Left Side Plate. Secure using four thumbscrews (item #4) and four external tooth star washers (item #5).
3. **Orient the Burglary Module** above the motherboard with its terminals towards the left side. On the right side of the Burglary Module is a polarized 12 pin female ribbon connector "J2"; insert J2 into the male 12 pin connector "J8" on the motherboard. Using the four 6-32 screws, mount the Burglary Module to the two HW1490 Support Bars (if not already pre-assembled).

TERMINAL DESCRIPTIONS

Maximum Burglary alarm and standby current can not exceed calculated maximum available *Power Supply Current* or *Available Battery Standby Current*, whichever is less. Typically, this is determined by the *Available Battery Standby Current*. Both must be calculated using detailed spreadsheets to be created and provided for review by the authority having jurisdiction.

Note: There are no integral burglary zones. Burglary zones require either GEMC-EZM's wired to the Burg Bus, SLC's connected to the motherboard, or a wireless receiver (GEMC-RECV) wired to the Fire bus (may be wired to the Burg bus on a Burg-only system).

BELL ("Bell Output")

Terminal 1: Burg (+)

Terminal 2: Burg (-)

Supervised for open; use only one bell for proper supervision. Do not wire to Fire devices. Power limited output.

AUX PWR

Terminal 3: Aux Power (+)

Terminal 4: Aux Power (-)

Separate Burglary Auxiliary Power for Burglary peripherals such as PIR's. Power limited output. Do not wire to Fire devices.

PGM1, 2

Terminal 5, 6: PGM1 (-), PGM2 (-)

Programmable by zone, active low open collector outputs. Do not wire to Fire devices.

BURG BUS ("Remote Bus")

Terminal 7: Remote (+)

Terminal 8: Remote (-)

Terminal 9: Remote GRN

Terminal 10: Remote YEL

Do not wire to Fire devices.

Peripherals: GEMC-BK1 (at least one required), GEMC-EZM, GEMC-OUT8, GEMC-RM3008, GEM-ACM1D and GEMC-RECV. Separate Burglary Bus supports all existing Gemini C-Series burglary peripherals and a maximum of 15 keypads (using separate UL603 or UL1481 listed power supply, model GEMC-12V2APS-CF or GEMC-12V2APS-R).

AUX RELAY

Terminal 11: COM

Terminal 12: N/C

Terminal 13: N/O

JP2 (Burg Service Jumper)

For Combination Fire and Burglary systems. When the shunt is placed on the two left pins ("ON") of this three-pin jumper, the system enters a special mode named "Burg Service Mode" where the system stops processing Burglary (non-Fire) alarm functions to permit the Burglary part of the system to be serviced (changed) *while allowing the Fire system to continue to function as intended*. When servicing the Burglary system, we recommend entering Burg Service Mode before removing power to avoid the various troubles (such as a Burg keypad trouble) that will occur. When Burg Service Mode is on, an LED located just below the jumper will light. A Burg Service Mode jumper is also located on the control panel motherboard that is in parallel with the JP2 jumper on the GEMC-BM/PS; either jumper can be used to initiate Burg Service Mode, and the LED located just below the jumper will light.

JP3 (No Time Out / 4.5 Hour Limit AC Fail Jumper)

The GEMC-BM draws all of its power from the control panel motherboard. This three-pin jumper allows for the selection of one of two options if the motherboard loses AC power:

NO TIME OUT: Place the shunt on the two left pins (or remove the shunt entirely) for power to be provided to the GEMC-BM (and its connected devices) from the motherboard until the battery power supplying the motherboard is exhausted (and consequently both the motherboard and the GEMC-BM Burglary module will no longer be powered). The jumper is placed on these two right pins ("**NO TIME OUT**") at the factory.

TIMED LIMIT AC FAIL: Not recommended to be enabled for Burglary Only systems. If the motherboard loses AC power and the shunt is placed on the two right pins, motherboard battery power will be provided to the GEMC-BM (and its connected devices) for the programmed entry in the **System Assignment** screen **Time Selection** tab, the **Shed Burg on AC Fail** field (the number entered is x10 minutes). After the selected time, power to the GEMC-BM will cease, thus conserv-

ing power for the Fire portion of a Fire/Burg combination system (or a Fire-Only system). In UL installations, the number entered should be either zero ("un-timed") or enter "27" (equal to 4 hours and 30 minutes). When calculating system battery Standby time, use this field for entering the number of standby Amp-Hours required for the Burg portion of the system.

J2 (Motherboard Socket Connector)

12 pin data connector to allow a data connection between the motherboard and the GEMC-BM Burglary module.

GEMC-BM WIRING DIAGRAM

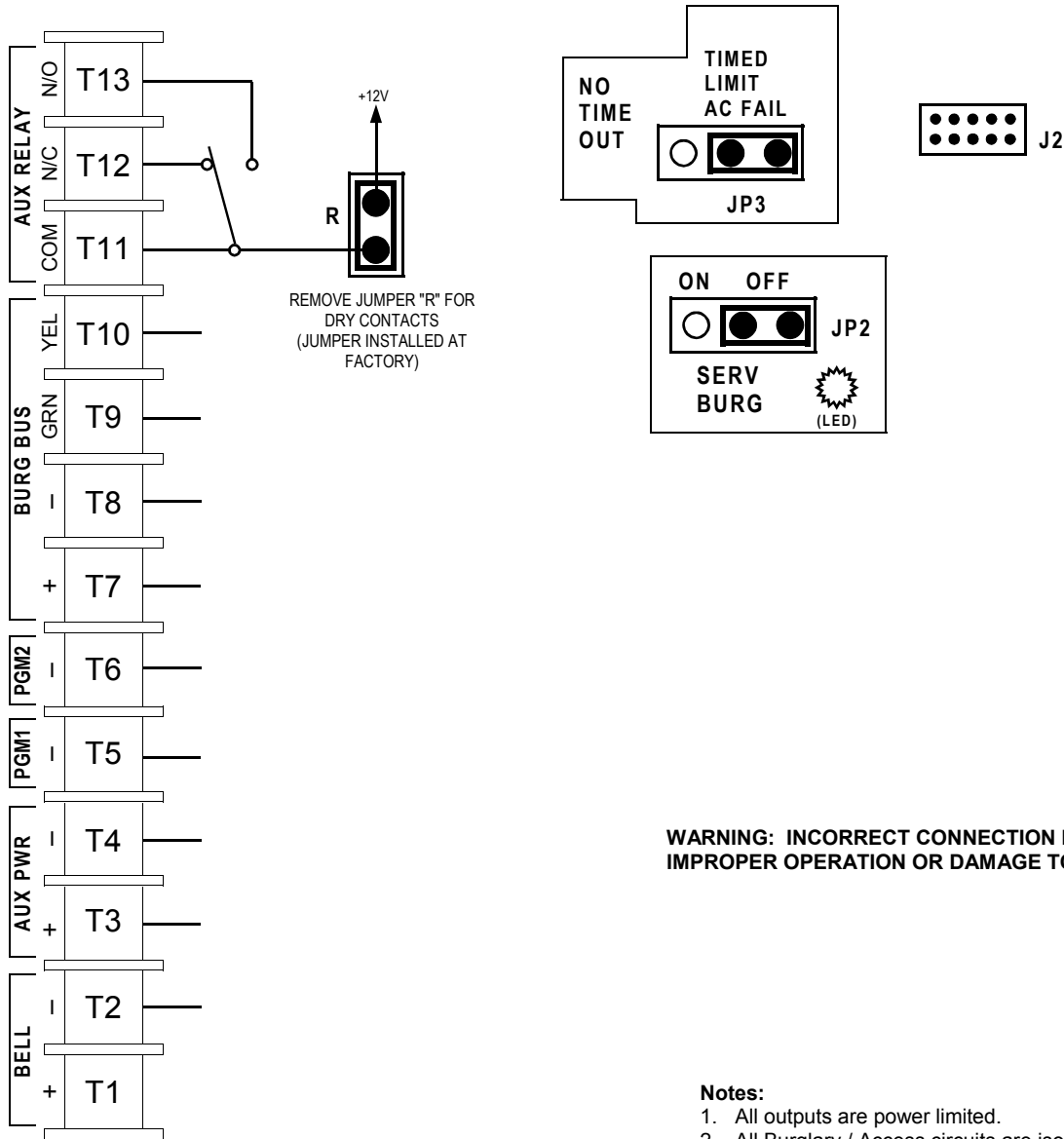

WARNING: INCORRECT CONNECTION MAY RESULT IN IMPROPER OPERATION OR DAMAGE TO THE SYSTEM.

Notes:

- 1. All outputs are power limited.
- 2. All Burglary / Access circuits are isolated from Fire circuits.
- 3. Wire range 14-22 AWG.

NAPCO LIMITED WARRANTY

NAPCO SECURITY SYSTEMS, INC. (NAPCO) warrants its products to be free from manufacturing defects in materials and workmanship for *thirty-six months* following the date of manufacture. NAPCO will, within said period, at its option, repair or replace any product failing to operate correctly without charge to the original purchaser or user.

This warranty shall not apply to any equipment, or any part thereof, which has been repaired by others, improperly installed, improperly used, abused, altered, damaged, subjected to acts of God, or on which any serial numbers have been altered, defaced or removed. Seller will not be responsible for any dismantling or reinstallation charges.

THERE ARE NO WARRANTIES, EXPRESS OR IMPLIED, WHICH EXTEND BEYOND THE DESCRIPTION ON THE FACE HEREOF. THERE IS NO EXPRESS OR IMPLIED WARRANTY OF MERCHANTABILITY OR A WARRANTY OF FITNESS FOR A PARTICULAR PURPOSE. ADDITIONALLY, THIS WARRANTY IS IN LIEU OF ALL OTHER OBLIGATIONS OR LIABILITIES ON THE PART OF NAPCO.

Any action for breach of warranty, including but not limited to any implied warranty of merchantability, must be brought within the six months following the end of the warranty period. IN NO CASE SHALL NAPCO BE LIABLE TO ANYONE FOR ANY CONSEQUENTIAL OR INCIDENTAL DAMAGES FOR BREACH OF THIS OR ANY OTHER WARRANTY, EXPRESS OR IMPLIED, EVEN IF THE LOSS OR DAMAGE IS CAUSED BY THE SELLER'S OWN NEGLIGENCE OR FAULT.

In case of defect, contact the security professional who installed and maintains your security system. In order to exercise the warranty, the product must be returned by the security professional, shipping costs prepaid and insured to NAPCO. After repair or replacement, NAPCO assumes the cost of returning products under warranty. NAPCO shall have no obligation under this warranty, or otherwise, if the product has been repaired by others, improperly installed, improperly used, abused, altered, damaged, subjected to accident, nuisance, flood, fire or acts of God, or on which any serial numbers have been altered, defaced or removed. NAPCO will not be responsible for any dismantling, reassembly or reinstallation charges.

This warranty contains the entire warranty. It is the sole warranty and any prior agreements or representations, whether oral or written, are either merged herein or are expressly cancelled. NAPCO neither assumes, nor authorizes any other person purporting to act on its

behalf to modify, to change, or to assume for it, any other warranty or liability concerning its products.

In no event shall NAPCO be liable for an amount in excess of NAPCO's original selling price of the product, for any loss or damage, whether direct, indirect, incidental, consequential, or otherwise arising out of any failure of the product. Seller's warranty, as hereinabove set forth, shall not be enlarged, diminished or affected by and no obligation or liability shall arise or grow out of Seller's rendering of technical advice or service in connection with Buyer's order of the goods furnished hereunder.



NAPCO RECOMMENDS THAT THE ENTIRE SYSTEM BE COMPLETELY TESTED WEEKLY.

Warning: Despite frequent testing, and due to, but not limited to, any or all of the following; criminal tampering, electrical or communications disruption, it is possible for the system to fail to perform as expected. NAPCO does not represent that the product/system may not be compromised or circumvented; or that the product or system will prevent any personal injury or property loss by burglary, robbery, fire or otherwise; nor that the product or system will in all cases provide adequate warning or protection. A properly installed and maintained alarm may only reduce risk of burglary, robbery, fire or otherwise but it is not insurance or a guarantee that these events will not occur. CONSEQUENTLY, SELLER SHALL HAVE NO LIABILITY FOR ANY PERSONAL INJURY, PROPERTY DAMAGE, OR OTHER LOSS BASED ON A CLAIM THE PRODUCT FAILED TO GIVE WARNING. Therefore, the installer should in turn advise the consumer to take any and all precautions for his or her safety including, but not limited to, fleeing the premises and calling police or fire department, in order to mitigate the possibilities of harm and/or damage.

NAPCO is not an insurer of either the property or safety of the user's family or employees, and limits its liability for any loss or damage including incidental or consequential damages to NAPCO's original selling price of the product regardless of the cause of such loss or damage.

Some states do not allow limitations on how long an implied warranty lasts or do not allow the exclusion or limitation of incidental or consequential damages, or differentiate in their treatment of limitations of liability for ordinary or gross negligence, so the above limitations or exclusions may not apply to you. This Warranty gives you specific legal rights and you may also have other rights which vary from state to state.

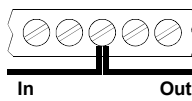
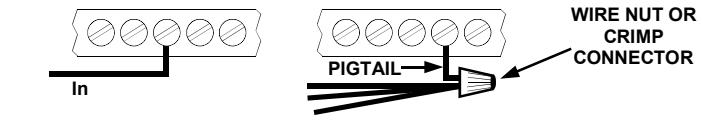
IMPORTANT WIRING METHODS

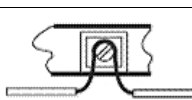
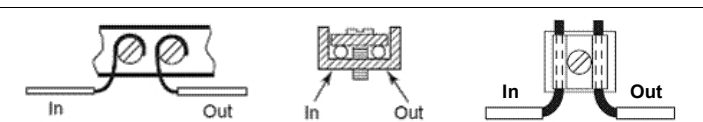
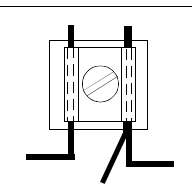
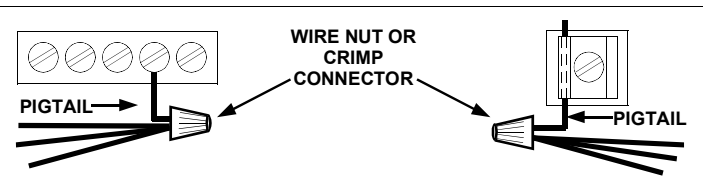
 <p>For single-conductor terminal blocks (like the type shown at left), to terminate more than one conductor to a terminal, use the wiring methods shown at right:</p>	 <p>In</p> <p>Out</p> <p>Incorrect</p>	 <p>WIRE NUT OR CRIMP CONNECTOR</p> <p>PIGTAIL</p> <p>In</p> <p>Out</p> <p>Correct -- Single incoming and/or pigtail with wire nut / crimp connectors</p>
 <p>For "barrier" type terminal blocks (like the type shown at left), to terminate two conductors to a terminal, use the wiring methods shown at right:</p>	 <p>In</p> <p>Out</p> <p>Incorrect</p>	 <p>In</p> <p>Out</p> <p>In</p> <p>Out</p> <p>In</p> <p>Out</p> <p>Correct -- Separate incoming and outgoing conductors</p>
<p>To terminate more than two conductors or conductors of different wire sizes to a terminal, use the "pigtail" type wiring method as shown at right. Use insulated wire for the pigtail, and firmly secure the conductors to the pigtail using an appropriate wire nut or crimp connector for the number and gauge of conductors used.</p>	 <p>In</p> <p>Out</p> <p>Incorrect</p>	 <p>WIRE NUT OR CRIMP CONNECTOR</p> <p>PIGTAIL</p> <p>PIGTAIL</p> <p>In</p> <p>Out</p> <p>Correct -- Use pigtail and wire nut / crimp connector</p>