



333 Bayview Avenue
Amityville, New York 11701
For Sales and Repairs, (800) 645-9445
For Technical Service, (800) 645-9440
Publicly traded on NASDAQ Symbol: NSSC

© NAPCO 2010

GEMC-12V2APS-CF, GEMC-12V2APS-R & GEMC-12V2ABOARD REGULATED POWER SUPPLY INSTALLATION INSTRUCTIONS

WI1828A 08/10

OVERVIEW

There are two versions of the GEMC-12V2APS: GEMC-12V2APS-CF (Commercial Fire) contains a transformer mounted inside the housing that requires a licensed electrician to wire. The GEMC-12V2APS-R (Residential Fire/Burglary, Commercial Burglary) is without a transformer mounted inside the housing. It uses a plug-in 16.5VAC, 50VA class 2 transformer that does not require an electrician to wire. Both versions use the GEMC-12V2ABOARD UL Listed Subassembly. The GEMC-12V2APS-CF or GEMC-12V2APS-R can be used as either:

- A UL Listed Accessory to a Gemini C-Series Combination Fire & Burglary Alarm control panel and GEMINI series control panels (GEM-X255, GEM-P9600, GEM-P3200, Freedom F-64, GEM-P1664, GEM-P1632 and GEM-P816).

--or--

- A UL Listed power supply for use with any listed Fire Alarm Control Panel (FACP), burglary control panel or access control system requiring an additional 12VDC auxiliary power

Both versions use the GEMC-12V2ABOARD UL Listed subassembly, suitable for use as a replacement board. The dual nature of the power supplies requires this manual be divided into two individual sections: When the GEMC-12V2APS is used with the Gemini C-Series control panels, proceed to the next section named "**GEMINI C-SERIES OPERATION**" directly below. When used with a Listed Control Panel as a stand-alone power supply, stop here and turn to page 11.

LISTINGS

- UL1481 (for -CF only)
- UL603
- NFPA 72 compliant
- UL985

GEMINI C-SERIES OPERATION

INTRODUCTION

When used with a Gemini C-Series control panel, the GEMC-12V2APS functions as an auxiliary 12V power supply with an integral **EZM** (Expansion Zone Module) used to send the status of the module (AC ON/OFF, BATTERY GOOD/TBL and TAMPER) to the control panel. The GEMC-12V2APS is wired to the 4-wire fire bus of the C-Series control panel, and provides:

- 3-Unsupervised active-low 2A outputs activated by AC FAIL, BATTERY TBL and MICRO TBL.
- One supervised GEMC-Remote Bus interface
- One normally-closed (N/C) housing tamper input, identified by trouble on dedicated integral EZM zone
- 4 status LED's
- Power supply contains integral battery charger capable of charging up to 1 pair of 12AH/12V sealed lead acid batteries
- The system monitors for low battery, no battery, brown-out* and monitors battery charging circuit voltage, identified by trouble on dedicated integral EZM zone
- Solid State over-current protection
- Integral housing tamper switch inputs to protect against the unauthorized opening of the housing cover and a rear tamper protecting removal of the housing from its

mounting surface

- The maximum number of GEMC-12V2APS's can be used on a Gemini C-Series control panel is determined by the number of available EZM's to monitor status. Each GEMC-12V2APS requires 3 zones (AC FAIL, BATT TBL and TBL) of the 4 EZM zones.
- Cabinet included
- Automatic switchover to stand-by battery when AC Fails
- In Commercial installations, the power supplies are not to be employed as a power source for local audible alarm sounding devices or for off-premises alarm transmitter/communicators.

GEMC-12V2APS-CF SPECIFICATIONS

Electrical Ratings

(Use dedicated 15A circuit for input power)

Primary Input Power: 120VAC, 60Hz, 1A.

Secondary Input Power: Minimum two 12V / 4AH batteries; two 12AH batteries maximum (see **Standby Current Charts** for battery requirements).

Total Output Power: 12VDC, 2A maximum combined alarm and standby current (less 40mA standby current for power supply board).

Two Auxiliary Power Outputs: 12V Regulated, 1.5A

*Brownout only required for Commercial Fire applications. Remove "Enable Brownout Detection" shunt for non-Commercial Fire Applications.

maximum each; 0.80A @ 12V combined maximum standby current for 24 hours.

Standby Current: 40mA for main board (subtract from overall rating).

Additional Specifications (for GEMC-12V2APS-CF and GEMC-12V2APS-R)

NO AC: Active Low, switches up to 2A DC. Normally active, turns off when no AC or brownout is detected. Connect to power-limited circuits only, 30VDC maximum.

BAT TBL: Active Low, switches up to 2A DC. Normally active, turns off when no battery, low battery and/or battery charging circuit trouble is detected. Connect to power-limited circuits only, 30VDC maximum.

TBL: Active Low, switches up to 2A DC. Normally active, turns off when microprocessor stops functioning, no AC, brownout or battery trouble. Connect to power-limited circuits only, 30VDC maximum.

Operating Temperature: 32°F to 120°F (0°C to 49°C).

Operating Humidity Range: Maximum 85% relative humidity @ 30°C.

Enclosure Dimensions (WxHxD): Inches: 13.875" x 12.375" x 3.80" (enclosure not provided with the GEMC-12V2ABOARD)

GEMC-12V2APS-R SPECIFICATIONS

Electrical Ratings

Primary Input Power: 120VAC, 60Hz, 60W (NAPCO TRF-14).

Secondary Input Power: Two 12AH batteries maximum.

Total Output Power: 2.1A minus selected charging current. (see **JUMPERS** section for charging current selections).

Two Auxiliary Power Outputs: 12V Regulated, 1.5A maximum each; 0.80A @ 12V maximum standby current for 24 hours (see **GEMC-12V2APS BATTERY / CURRENT SPECIFICATIONS** tables).

Standby Current: 40mA for main board (less 40mA standby current for power supply board).

Housing

The GEMC-12V2APS comes complete with transformer, enclosure and ample room for standby batteries. Each

model requires either two 12V 4AH, 4.5AH, 5AH batteries, two 12V 7AH, 7.5AH, 8AH batteries or two 12V / 12AH batteries.

Programming

When used with a Gemini C-Series control panel, the integral EZM must be programmed and the PC board must be configured correctly with its jumper options. For Programming, turn to page 4. When using PCD-Windows Quickloader, select **System Assignment** screen, **EZM Assignments** tab, and click the **Type** pull-down menu and select "4 Zone PS".

JUMPERS

When used with a Gemini C-Series control panel, the jumpers on the GEMC-12V2ABOARD are used as follows:

EZM ADDR: Use to configure the integral 4-Zone EZM to send the status of a device (AC ON/OFF, BATTERY GOOD/TBL and TAMPER) to the C-Series control panel.

ENABLE BROWNOUT (Required for Commercial Fire): If enabled (shunt installed) the power supply detects if the 120VAC input drops below 85% and generates an AC Fail trouble. The brownout Shunt is installed at the factory. Brownout is required in Commercial Fire installations. Shunt can be removed in Burglary and Residential Fire applications, and must be removed when the 16.5VAC / 50VA plug-in transformer is used.

CHARGING CURRENT: Use to configure battery charging current. Install both shunts for 1A battery charging current. Remove J5 shunt only for 750mA battery charging current. Remove J6 shunt only for 350mA battery charging current (see **Standby Current Charts** for required jumper settings).

INSTALLATION

The GEMC-12V2APS must be installed in accordance with NFPA 70, NFPA 72 and with article 760 of The National Electrical Code as well as all applicable local codes. Ensure the 120VAC branch circuit breaker is turned off before proceeding.

When used with a Gemini C-Series control panel, install the GEMC-12V2APS-CF as follows:

LED STATUS INDICATION TABLE (for inputs, outputs & trouble memory status)			
LED NAME	OFF	ON	FLASH TYPE*
EZM STATUS	No Power	Power on but no poll	(Short Flash is "normal") Rapid flash indicates charging circuit trouble
BAT TBL	Normal	Low battery, no battery or charging circuit trouble	---
AC ON	AC Loss (running on battery)	AC present (with or without battery power)	---
TBL	Normal	Low battery, no battery or charging circuit trouble, AC Loss (running on battery), tamper indication, microprocessor failure, or overcurrent on Aux 1 or Aux 2.	---
PWR	No Power	Power present	---
AUX 1	Normal	Output Overload	---
AUX 2	Normal	Output Overload	---

* May indicate trouble condition.

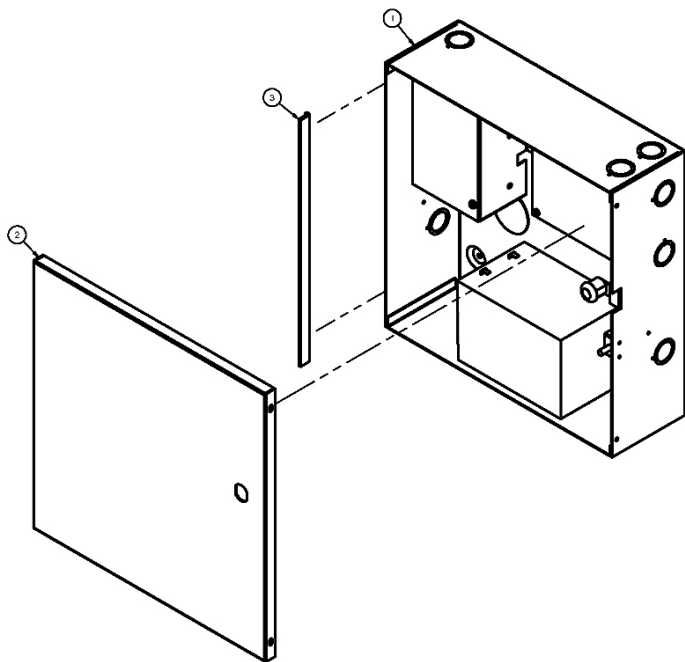

EXPLODED VIEW OF GEMC-12V2APS ENCLOSURE.

- (1) - HOUSING BASE (PART H457)
- (2) - HOUSING COVER (PART H458)
- (3) - HINGE (PART P5655)

Ensure the 120VAC branch circuit breaker remains turned OFF before proceeding.

1. Select a suitable location for the GEMC-12V2APS enclosure, ensuring that adequate space is available for mounting the enclosure on a wall with no interference from wires, pipes, or other obstructions. Mount the enclosure using fasteners suitable for the mounting surface. The mounting surface must be capable of supporting 20 pounds (6.3Kg) plus any additional weight of the installation hardware.
2. A licensed electrician must route a continuously-powered 120VAC source with a maximum 15A dedicated branch circuit with grounding conductor in accordance with all national and local electrical codes. Route the three wires (hot/black, neutral/white and earth ground/green/bare copper) through the upper left side housing knockout directly to the three wires marked "HOT" (black), "NEUTRAL" (white) and "EG" (green/bare copper) using connectors suitable for the application.

Note: The Earth Ground wire must always be the first connected to the "EG" terminal and last disconnected from the "EG" terminal and secured by a separate nut.
3. Turn on the 120VAC branch circuit breaker.

Maintenance

The GEMC-12V2APS should be tested at least once a month for proper operation as follows:

Output Voltage Test: Under normal load conditions, the DC output voltage should be checked for proper voltage levels (12.0 VDC nominal).

Battery Test: Under normal load conditions check that the battery is fully charged (approximately 13.5 to

13.8VDC). Check the voltage at the battery terminal and at the board terminal marked [-BAT +] to insure there is no break in the battery connection wires.

Note: Maximum charging rate is 1.5A. Expected battery life is approximately five years, however it is recommended changing batteries in four years or less if needed.

Overcurrent Protection

The battery pairs are protected with two 3A overcurrent protection devices. If batteries are mis-wired, a battery trouble will be initiated (refer to **LED STATUS INDICATION TABLE**). In addition, the GEMC-12V2ABOARD has a **RESET** button and two LED's used to indicate over-current (or short) with the associated output.

- When an over-current condition (or short) is detected on the **AUX 1** output, the 12V output will turn off and the AUX 1 fault LED will turn on.
- When an over-current condition (or short) is detected on the **AUX 2** output, the 12V output will turn off and the AUX 2 fault LED will turn on.

In either condition, the output will remain off until the **RESET** button is pressed and held for one second, then released, and the over-current condition (short) is no longer present.

Fuse Replacement: For model "GEMC-12V2APS-CF" only; order Napco part W1025 (blue-wire harness).

TERMINAL DESCRIPTIONS

1. (+) AUX 1
2. (-) AUX 1
3. (+) AUX 2
4. (-) AUX 2
Auxiliary power outputs rated 12VDC regulated, 2A maximum. Maximum combined alarm + standby current output is 2A (less 40mA standby current for power supply board).
5. (-) NO AC
Optional output: Active Low 2A Output. Normally active turns off when no AC or brownout is detected. Connect to power limited circuits only, 30VDC maximum.
6. (-) BAT TBL
Active Low 2A Output. Normally active turns off when no battery, low battery and/or battery charging circuit trouble is detected. Connect to power limited circuits only, 30VDC maximum.
7. (-) TBL
Active Low 2A Output. Normally active turns off when microprocessor stops functioning, no AC, brownout or battery trouble. Connect to power limited circuits only, 30VDC maximum.
8. (+) REMOTE
9. (-) REMOTE
10. (-) REMOTE GRN
11. (+) REMOTE YEL
Terminals 8 through 11 are remote bus inputs. When power supply is used for Fire functions, it must be wired to the 4-wire Fire bus of the GEMINI C-Series control panel.

When power supply is used for Burglary functions, it must be wired to the 4-wire Burg bus of the GEMC-BM or GEMC-BM/PS module.

12. (+) TAMPER

Housing tamper positive terminal. Used with a zone dedicated to "Tamper" within the integral 4-Zone EZM; when a tamper is detected, a report will be sent to the control panel as the 3rd zone of the EZM through the 4-wire fire bus. Use front and back housing tamper switches, normally open when not installed, normally closed in the circuit, and open when activated (we recommend using a GEMC-TAMPERKIT). Wire the negative tamper to terminal 9 ("**-** REMOTE").

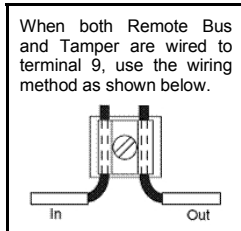

Note: The activation of Tamper is reported to the panel using the 3rd zone of the NAC integral EZM; program the integral EZM using the Quickloader **EZM Assignment** screen and **Zone Assignment** screens, as shown in the section "**PROGRAMMING**".

Note: Tamper can be disabled by not programming the associated tamper zone features, thus leaving the zone undefined with no area assigned, or with appropriate features for the wireless / BSLC device. **Note:** Must satisfy tamper between terminals 9 and 12 when not used.

WIRING

Before wiring, you must determine if the GEMC-12V2ABOARD will be used for either Fire or for Burglary functions. For Fire functions, wire to the Fire Bus on the GEMINI C-Series control panel; for Burglary functions, wire to the Burg bus on the GEMINI C-Series control panel.

PROGRAMMING

Use the Integral 4-Zone EZM to Monitor GEMC-12V2ABOARD Troubles

To program the integral EZM, PCD-Windows Quickloader download software must be used. Before programming, prepare PCD-Windows Quickloader as follows:

1. If not open already, open the **Zone Assignment** screen by pressing **Ctrl+Shift+Z** on the keyboard.
2. If not open already, click **View, Workspace** to open the Workspace panel. Notice the **Zone Assignment** field is highlighted in the Workspace.
3. If the **Zone Type** column is not already displayed, click the **Show Zone Types** button.

To program 4-Zone Fire Power Supply Troubles:

1. Open the **System Assignment** screen, **EZM Assignments** tab.
2. In the **Type** column for the selected EZM row, click the intersecting field and select **4-Zone Fire PS** from the **Type** pull-down menu.
If **EZM 2** (zones 13-16) is selected, notice the **Zone Assignment** screen automatically populates each selected zone with "zFire Monitor" for the **Zone Type** and a "1" for the **Area**, and the following for **Description** and **Adv. Code**:

Description

Adv. Code

013-PWR SUPPLY 02 AC Fail TBL..... AC Fail
014-PWR SUPPLY 02 Battery TBL..... Low Battery
015-PWR SUPPLY 02 Tamper TBL..... Fire EZM Tamper

Note: Tamper zone monitoring is not required by UL or NFPA for Fire applications, and the zone can be changed back to an undefined state, without an Area assigned to the zone. In addition, in this example, zone 16 is unassigned, and can be utilized for other purposes if needed.

Note: Zone four is not used; but can be wired to a wireless transmitter or SLC point.

To program 4-Zone Burglary Power Supply Troubles:

1. Open the **System Assignment** screen, **EZM Assignments** tab.
2. In the **Type** column for the selected EZM row, click the intersecting field and select **4-Zone Burg PS** from the **Type** pull-down menu.

If **EZM 3** (zones 17-20) is selected, notice the **Zone Assignment** screen automatically populates each selected zone with "zBurg Monitor" for the **Zone Type** and a "2" for the **Area**, and the following for **Description** and **Adv. Code**:

Description

Adv. Code

017-PWR SUPPLY 03 AC Fail TBL.... AC Fail
018-PWR SUPPLY 03 Battery TBL Low Battery
019-PWR SUPPLY 03 Tamper TBL ... Tamper

Note: Tamper zone monitoring is not required (except in Access Control applications; tamper zone monitoring is for the door tamper as required for access control, UL 294), and the zone can be changed back to an undefined state, without an Area assigned to the zone. In addition, in this example, zone 20 is unassigned, and can be utilized for other purposes if needed.

Note: Zone four is not used; but can be wired to a wireless transmitter or SLC point.

GEMC-12V2APS BATTERY / CURRENT SPECIFICATIONS

GEMC-12V2APS-R, GEMC-12V2ABOARD RESIDENTIAL BURGLARY BATTERY / CURRENT SPECIFICATIONS						
BATTERY CONFIGURATION	JUMPER SELECTION			MAXIMUM 4 HOUR 12V STANDBY CURRENT* (RESIDENTIAL BURG)	MAXIMUM 24 HOUR 12V STANDBY CURRENT*	MAXIMUM 12V STANDBY + ALARM CURRENT*
	SHUNT 5	SHUNT 6	RECHARGE CURRENT (mA)			
TWO 12V 4AH, 4.5AH, 5AH	OFF	ON	750	1.25A	0.250A	1.35A
TWO 12V 7AH, 7.5AH	OFF	ON	750	1.35A	0.500A	1.35A
TWO 12V 8AH	OFF	ON	750	1.35A	0.550A	1.35A
TWO 12V 12AH	ON	ON	1000	1.1A	0.85A	1.1A

GEMC-12V2APS-R, GEMC-12V2ABOARD COMMERCIAL BURGLARY BATTERY / CURRENT SPECIFICATIONS						
BATTERY CONFIGURATION	JUMPER SELECTION			MAXIMUM 4 HOUR 12V STANDBY CURRENT*	MAXIMUM 24 HOUR 12V STANDBY CURRENT*	MAXIMUM 12V STANDBY + ALARM CURRENT*
	SHUNT 5	SHUNT 6	RECHARGE CURRENT (mA)			
TWO 12V 4AH, 4.5AH, 5AH	OFF	ON	750	1.25A	0.250A	1.35A
TWO 12V 7AH, 7.5AH	OFF	ON	750	1.35A	0.500A	1.35A
TWO 12V 8AH	OFF	ON	750	1.35A	0.550A	1.35A
TWO 12V 12AH	ON	ON	1000	1.1A	0.85A	1.1A

GEMC-12V2APS-R, GEMC-12V2ABOARD RESIDENTIAL FIRE AND/OR COMBINATION RESIDENTIAL BURGLARY & FIRE BATTERY / CURRENT SPECIFICATIONS					
BATTERY CONFIGURATION	JUMPER SELECTION			MAXIMUM 24 HOUR 12V STANDBY CURRENT*	MAXIMUM 12V STANDBY + ALARM CURRENT*
	SHUNT 5	SHUNT 6	RECHARGE CURRENT (mA)		
TWO 12V 4AH, 4.5AH, 5AH	ON	OFF	350	0.250A	1.75A
TWO 12V 7AH	ON	OFF	350	0.500A	1.75A
TWO 12V 8AH	ON	OFF	350	0.550A	1.75A
TWO 12V 12AH	OFF	ON	750	0.85A	1.35A

GEMC-12V2APS-CF COMMERCIAL BURGLARY BATTERY / CURRENT SPECIFICATIONS						
BATTERY CONFIGURATION	JUMPER SELECTION			MAXIMUM 4 HOUR 12V STANDBY CURRENT*	MAXIMUM 24 HOUR 12V STANDBY CURRENT*	MAXIMUM 12V STANDBY + ALARM CURRENT*
	SHUNT 5	SHUNT 6	RECHARGE CURRENT (mA)			
TWO 12V 4AH, 4.5AH, 5AH	ON	ON	1000	1.25A	0.250A	1.75A
TWO 12V 7AH, 7.5AH	ON	ON	1000	2A	0.500A	2A
TWO 12V 8AH	ON	ON	1000	2A	0.550A	2A
TWO 12V 12AH	ON	ON	1000	1.1A	0.850A	2A

GEMC-12V2APS-CF COMMERCIAL FIRE BATTERY / CURRENT SPECIFICATIONS					
BATTERY CONFIGURATION	JUMPER SELECTION			MAXIMUM 24 HOUR 12V STANDBY CURRENT*	MAXIMUM 12V STANDBY + ALARM CURRENT*
	SHUNT 5	SHUNT 6	RECHARGE CURRENT (mA)		
TWO 12V 4AH, 4.5AH, 5AH	ON	ON	1000	0.250A	2A
TWO 12V 7AH, 7.5AH	ON	ON	1000	0.500A	2A
TWO 12V 8AH	ON	ON	1000	0.550A	2A
TWO 12V 12AH	ON	ON	1000	0.85A	2A

*Less 40mA standby current for power supply board

INTEGRAL EZM ADDRESS JUMPERS

The integral EZM Address must be selected for a valid address for the 4 system troubles to be sent back to the panel

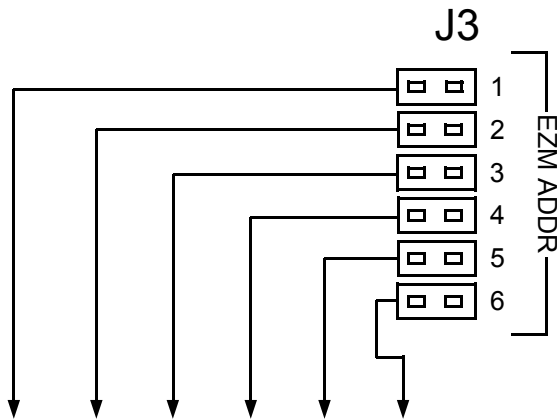

Base Address	1	2	3	4	5	6	Zones
1	ON	OFF	OFF	OFF	OFF	OFF	9-12
2	OFF	ON	OFF	OFF	OFF	OFF	13-16
3	ON	ON	OFF	OFF	OFF	OFF	17-20
4	OFF	OFF	ON	OFF	OFF	OFF	21-24
5	ON	OFF	ON	OFF	OFF	OFF	25-28
6	OFF	ON	ON	OFF	OFF	OFF	29-32
7	ON	ON	ON	OFF	OFF	OFF	33-36
8	OFF	OFF	OFF	ON	OFF	OFF	37-40
9	ON	OFF	OFF	ON	OFF	OFF	41-44
10	OFF	ON	OFF	ON	OFF	OFF	45-48
11	ON	ON	OFF	ON	OFF	OFF	49-52
12	OFF	OFF	ON	ON	OFF	OFF	53-56
13	ON	OFF	ON	ON	OFF	OFF	57-60
14	OFF	ON	ON	ON	OFF	OFF	61-64
15	ON	ON	ON	ON	OFF	OFF	65-68
16	OFF	OFF	OFF	OFF	ON	OFF	69-72
17	ON	OFF	OFF	OFF	ON	OFF	73-76
18	OFF	ON	OFF	OFF	ON	OFF	77-80
19	ON	ON	OFF	OFF	ON	OFF	81-84
20	OFF	OFF	ON	OFF	ON	OFF	85-88
21	ON	OFF	ON	OFF	ON	OFF	89-92
22	OFF	ON	ON	OFF	ON	OFF	93-96
23	ON	ON	ON	OFF	ON	OFF	97-100
24	OFF	OFF	OFF	ON	ON	OFF	101-104
25	ON	OFF	OFF	ON	ON	OFF	105-108
26	OFF	ON	OFF	ON	ON	OFF	109-112
27	ON	ON	OFF	ON	ON	OFF	113-116
28	OFF	OFF	ON	ON	ON	OFF	117-120
29	ON	OFF	ON	ON	ON	OFF	121-124
30	OFF	ON	ON	ON	ON	OFF	125-128
31	ON	ON	ON	ON	ON	OFF	129-132

to be annunciated/reported. Refer back to the section "PROGRAMMING" to determine the EZM Address to configure. The expansion zones are divided into consecutively-numbered groups of four. Each 4-zone module comprises one group of zones.

Every module must be assigned a unique base address. The base address number is the same as its group number.

Refer to the tables below for the "EZM ADDR" address jumper settings .

In the Quickloader, select the EZM type in the **System Assignment** screen, click the **EZM Assignments** tab and select the **Type** pull-down menu, select "4 Zone Burg PS" or "4 Zone Fire PS". The **EZM** column indicates the address that must be configured with the EZM address jumpers below.

Note: If using this product with the Gemini C-Series control panels, jumper **J3** should *NOT* be addressed as "zero" (with all shunts removed).

Base Address	1	2	3	4	5	6	Zones
32	OFF	OFF	OFF	OFF	OFF	ON	133-136
33	ON	OFF	OFF	OFF	OFF	ON	137-140
34	OFF	ON	OFF	OFF	OFF	ON	141-144
35	ON	ON	OFF	OFF	OFF	ON	145-148
36	OFF	OFF	ON	OFF	OFF	ON	149-152
37	ON	OFF	ON	OFF	OFF	ON	153-156
38	OFF	ON	ON	OFF	OFF	ON	157-160
39	ON	ON	ON	OFF	OFF	ON	161-164
40	OFF	OFF	OFF	ON	OFF	ON	165-168
41	ON	OFF	OFF	ON	OFF	ON	169-172
42	OFF	ON	OFF	ON	OFF	ON	173-176
43	ON	ON	OFF	ON	OFF	ON	177-180
44	OFF	OFF	ON	ON	OFF	ON	181-184
45	ON	OFF	ON	ON	OFF	ON	185-188
46	OFF	ON	ON	ON	OFF	ON	189-192
47	ON	ON	ON	ON	OFF	ON	193-196
48	OFF	OFF	OFF	OFF	ON	ON	197-200
49	ON	OFF	OFF	OFF	ON	ON	201-204
50	OFF	ON	OFF	OFF	ON	ON	205-208
51	ON	ON	OFF	OFF	ON	ON	209-212
52	OFF	OFF	ON	OFF	ON	ON	213-216
53	ON	OFF	ON	OFF	ON	ON	217-220
54	OFF	ON	ON	OFF	ON	ON	221-224
55	ON	ON	ON	OFF	ON	ON	225-228
56	OFF	OFF	OFF	ON	ON	ON	229-232
57	ON	OFF	OFF	ON	ON	ON	233-236
58	OFF	ON	OFF	ON	ON	ON	237-240
59	ON	ON	OFF	ON	ON	ON	241-244
60	OFF	OFF	ON	ON	ON	ON	245-248
61	ON	OFF	ON	ON	ON	ON	249-252

COMMERCIAL FIRE & RESIDENTIAL WIRING

WIRING THE GEMC-12V2APS TO AC (COMMERCIAL OR RESIDENTIAL FIRE, COMMERCIAL OR RESIDENTIAL BURGLARY)

There are two methods to wire the GEMC-12V2APS: The first is required for Commercial Fire applications using a transformer inside the housing as shown directly below. The second is for Residential applications using a 16.5VAC / 50VA plug-in transformer, as shown in the bottom diagram.

GEMC-12V2APS-CF POWER SUPPLY (12V)

120VAC WIRED TO UN-SWITCHED DEDICATED BRANCH CIRCUIT THROUGH RIGID CONDUIT.

WIRES ROUTED THROUGH CIRCULAR KNOCKOUT IN SIDE OF METAL ENCLOSURE

ALL WIRING OUTSIDE OF HIGH VOLTAGE COMPARTMENT IS POWER LIMITED OR DOUBLE INSULATED; THEREFORE SEPARATION FROM POWER-LIMITED FIELD WIRING IS NOT NECESSARY

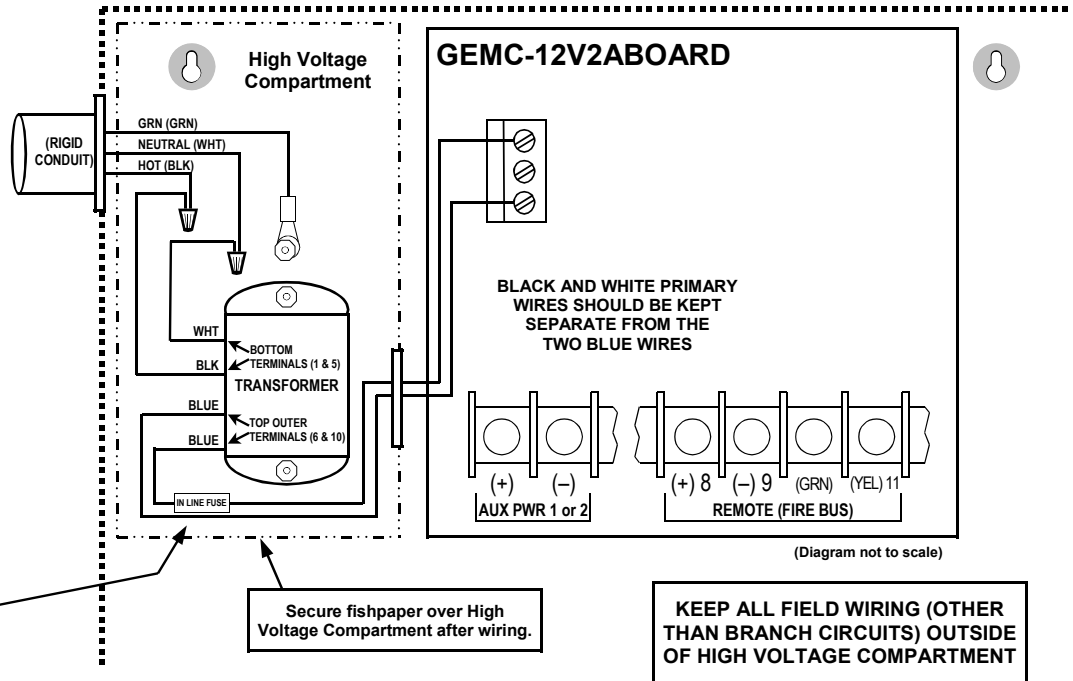

WIRING THE GEMC-12V2APS TO AC (RESIDENTIAL FIRE, RESIDENTIAL BURGLARY, COMMERCIAL BURGLARY)

GEMC-12V2APS-R POWER SUPPLY (12V)

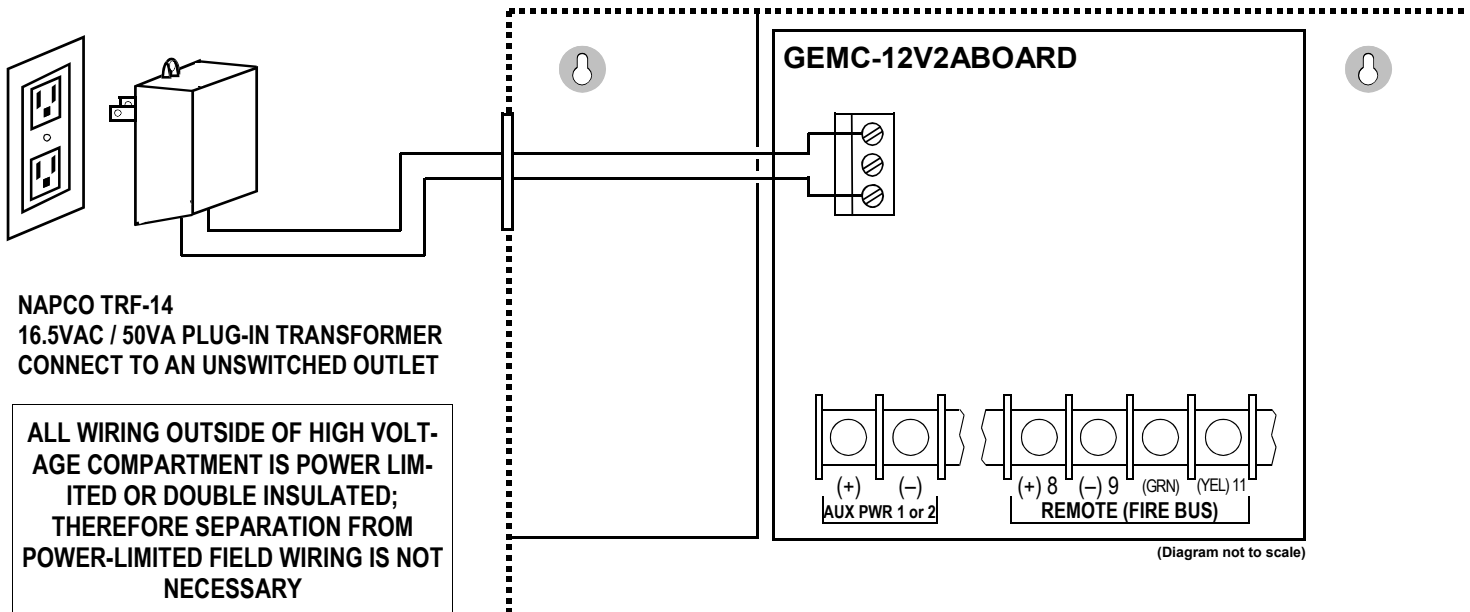

GEMINI C-SERIES CONTROL PANEL WIRING

Before proceeding, you must determine if the GEMC-12V2APS will be used for either Fire or for Burglary functions. For Fire functions, wire to the Fire Bus on the GEMINI C-Series control

panel as per the below diagram; for Burglary functions, wire to the Burg bus on the GEMINI C-Series control panel (see next page).

WIRE TO THE GEMC-XXXMB REMOTE FIRE BUS

Note: Terminal 18 of remote fire bus is not connected to those devices intended to be powered from the power supply.

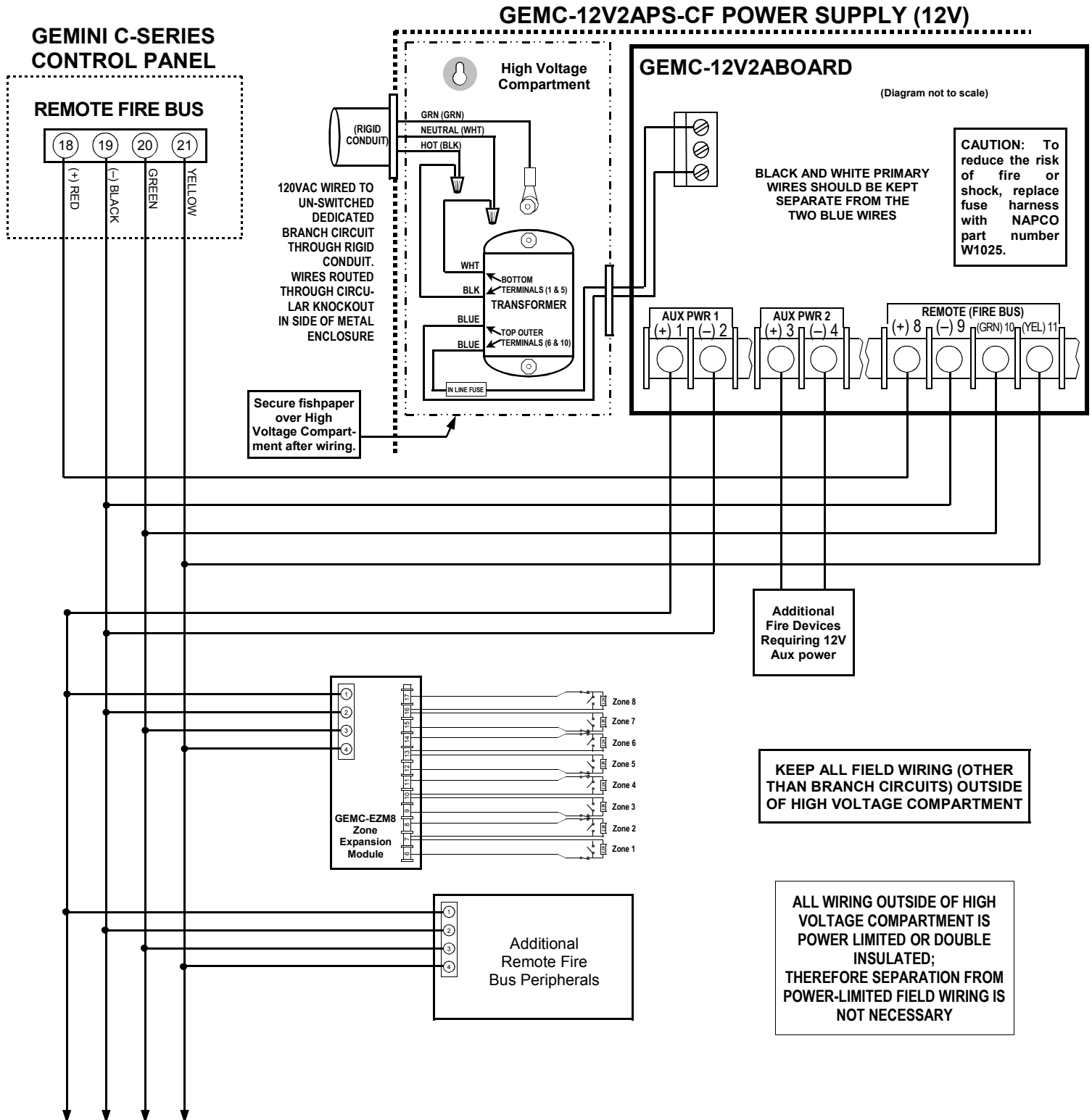

GEMINI C-SERIES CONTROL PANEL WIRING

WIRING THE GEMC-XXXMB REMOTE BURG BUS

Note: Terminal 7 of the remote fire bus is not connected to those devices intended to be powered from the power supply.
Note: The transformer shown in the diagram below shows the -R plug-in transformer configuration; the -CF configuration with 120VAC WIRED may be used in place of the -R configuration.

GEMC-12V2APS-R POWER SUPPLY (12V)

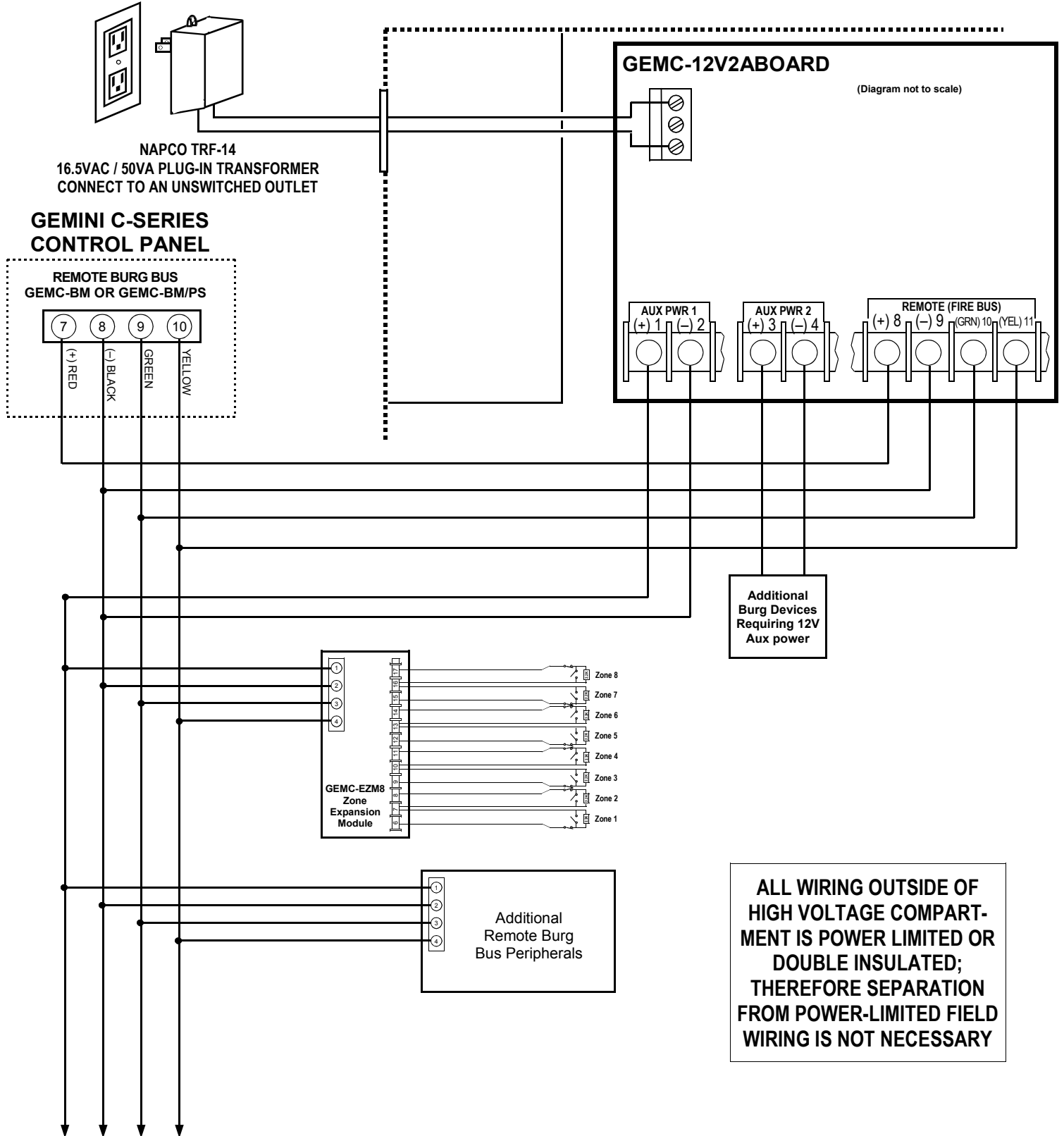

GEMINI CONTROL PANEL WIRING

WIRING THE GEM-SERIES REMOTE BUS

Note: Terminal 9 of the remote bus is not connected to those devices intended to be powered from the power supply. The following control panels may be wired as shown below: GEM-X255, GEM-P9600, GEM-P3200, Freedom F-64, GEM-P1664, GEM-P1632 and GEM-P816. **Note:** The transformer shown in the diagram below shows the -R plug-in transformer configuration; the -CF configuration with 120VAC WIRED may be used in place of the -R configuration.

GEMC-12V2APS-R POWER SUPPLY (12V)

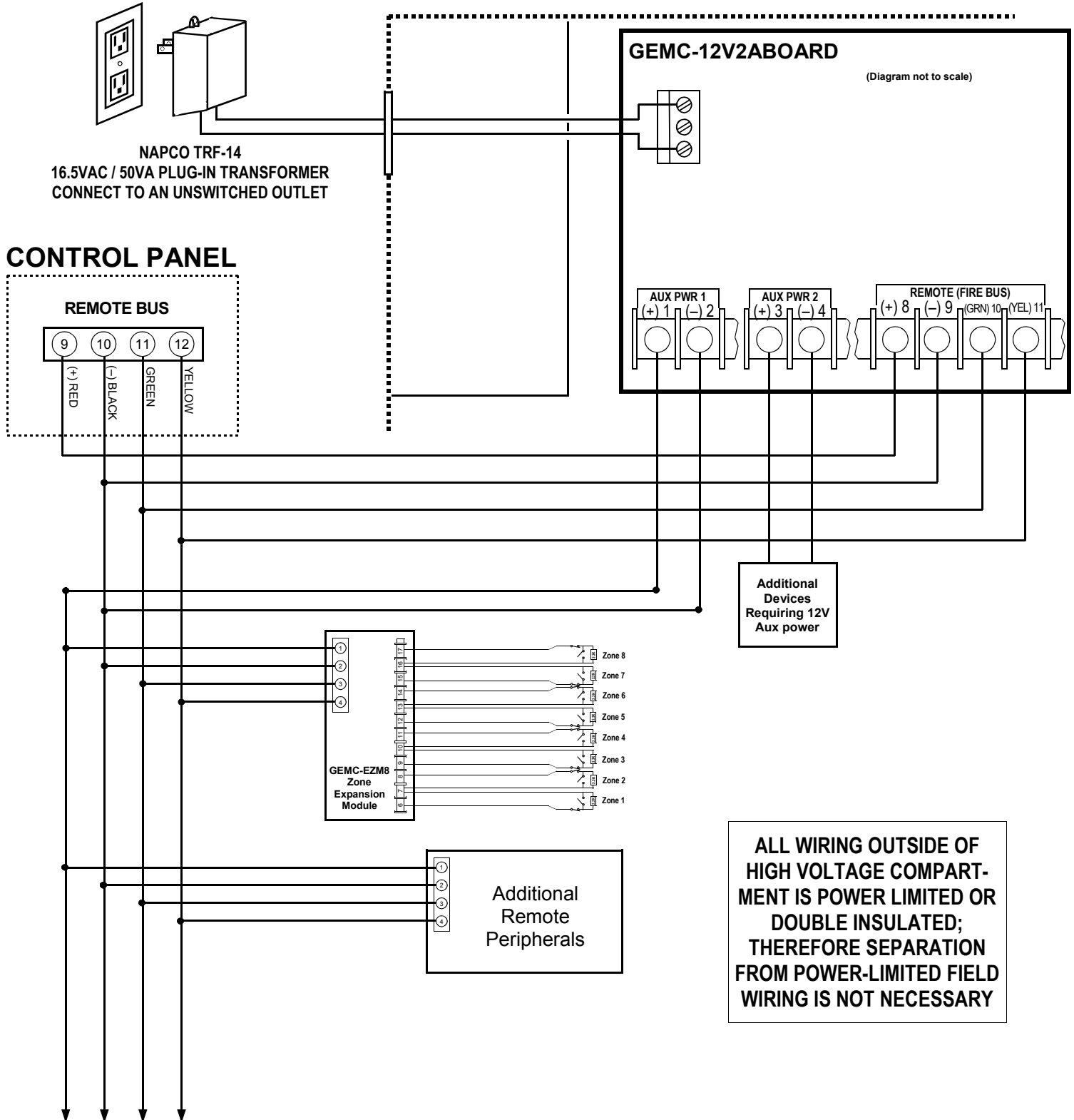

FACP, BURGLARY ALARM CONTROL PANEL OR ACCESS CONTROL UNIT AUXILIARY POWER SUPPLY INSTRUCTIONS

OVERVIEW

The GEMC-12V2APS-CF or GEMC-12V2APS-R can be used as a UL Listed auxiliary power supply for use with any FACP, Burglary Alarm Control Panel or Access Control Unit requiring an additional 12VDC auxiliary power. Both versions use the GEMC-12V2ABOARD UL Listed subassembly, suitable for use as a replacement board.

LISTINGS

- UL1481 (for -CF only)
- UL603
- NFPA 72 compliant
- UL985

INTRODUCTION

When used with any control panel or access control system, the GEMC-12V2APS functions as an auxiliary 12V power supply with 3 outputs that can be used to indicate status (AC ON/OFF, BATTERY GOOD/TBL and SYSTEM GOOD/TBL) to the control panel.

- 3-Unsupervised active-low 2A outputs activated by AC FAIL, BATTERY TBL and MICRO TBL.
- 4 status LED's
- Power supply contains integral battery charger capable of charging up to 1 pair of 12AH/12V sealed lead acid or gel type batteries
- The system monitors for low battery, no battery, brownout and monitors battery charging circuit voltage, identified by trouble on dedicated integral EZM zone
- Solid State over-current protection
- Integral housing tamper switch inputs to protect against the unauthorized opening of the housing cover and a rear tamper protecting removal of the housing from its mounting surface
- The maximum number of GEMC-12V2APS's can be used on a control panel is determined by the number of available zones to monitor status. When used for Fire, requires 3 zones; when used for Burglary, requires 2.
- Cabinet included
- Automatic switchover to stand-by battery when AC Fails
- In Commercial installations, the power supplies are not to be employed as a power source for local audible alarm sounding devices or for off-premises alarm transmitter/communicators.

GEMC-12V2APS-CF SPECIFICATIONS

Electrical Ratings

(Use dedicated 15A circuit for input power)

Primary Input Power: 120VAC, 60Hz, 1A.

Secondary Input Power: Minimum two 12V / 4AH batteries; two 12AH batteries maximum (see **Standby Cur-**

rent Charts for battery requirements).

Total Output Power: 12VDC, 2A maximum combined alarm and standby current.

Two Auxiliary Power Outputs: 12V Regulated, 1.5A maximum each; 0.80A @ 12V combined maximum standby current for 24 hours.

Standby Current: 40mA for main board (subtract from overall rating).

Additional Specifications (for GEMC-12V2APS-CF and GEMC-12V2APS-R)

NO AC: Active Low, switches up to 2A DC. Normally active, turns off when no AC or brownout is detected. Connect to power-limited circuits only, 30VDC maximum.

BAT TBL: Active Low, switches up to 2A DC. Normally active, turns off when no battery, low battery and/or battery charging circuit trouble is detected. Connect to power-limited circuits only, 30VDC maximum.

TBL: Active Low, switches up to 2A DC. Normally active, turns off when microprocessor stops functioning, no AC, brownout, battery trouble or over-current. Connect to power-limited circuits only, 30VDC maximum.

Operating Temperature: 32°F to 120°F (0°C to 49°C).

Operating Humidity Range: Maximum 85% relative humidity @ 30°C.

Enclosure Dimensions (WxHxD): Inches: 13.875" x 12.375" x 3.80" (enclosure not provided with the GEMC-12V2ABOARD)

Product Weight: Approximately 20 lbs.

GEMC-12V2APS-R SPECIFICATIONS

Electrical Ratings

Primary Input Power: 120VAC, 60Hz, 60W.

Secondary Input Power: Two 12AH batteries maximum.

Total Output Power: 2.1A minus selected charging current. (see **JUMPERS** section for charging current selections).

Two Auxiliary Power Outputs: 12V Regulated, 1.5A

maximum each; 0.80A @ 12V maximum standby current for 24 hours (see **GEMC-12V2APS BATTERY / CURRENT SPECIFICATIONS** tables).

Standby Current: 40mA for main board (subtract from overall rating).

Housing

The GEMC-12V2APS comes complete with transformer, enclosure and ample room for standby batteries. Each model requires either two 12V 7AH, 7.5AH, 8AH batteries or two 12V / 12AH batteries.

Programming

Associated control panel must have the zones programmed for the appropriate trouble indication and signaling.

JUMPERS

If using this product with a non-NAPCO control panel, jumper J3 should be addressed as zero without any shunts installed.

ENABLE BROWNOUT (Required for Commercial Fire): If enabled (shunt installed) the power supply detects if the 120VAC input drops below 85% and generates an AC Fail trouble. The brownout Shunt is installed at the factory. Brownout is required in Commercial Fire installations. Shunt can be removed in Burglary and Residential Fire applications, and must be removed when the 16.5VAC / 50VA plug-in transformer is used.

CHARGING CURRENT: Use to configure battery charging current. Install both shunts for 1A battery charging current. Remove J5 shunt only for 750mA battery charging current. Remove J6 shunt only for 350mA battery charging current (see **Standby Current Charts** for required jumper settings).

INSTALLATION

The GEMC-12V2APS must be installed in accordance with NFPA 70, NFPA 72 and with article 760 of The National Electrical Code as well as all applicable local codes. Ensure the 120VAC branch circuit breaker is turned off before proceeding.

Install the GEMC-12V2APS-CF as follows:

1. Select a suitable location for the GEMC-12V2APS enclosure, ensuring that adequate space is available for

mounting the enclosure on a wall with no interference from wires, pipes, or other obstructions. Mount the enclosure using fasteners suitable for the mounting surface. The mounting surface must be capable of supporting 20 pounds (6.3Kg) plus any additional weight of the installation hardware.

2. A licensed electrician must route a continuously-powered 120VAC source with a maximum 15A dedicated branch circuit with grounding conductor in accordance with all national and local electrical codes. Route the three wires (hot/black, neutral/white and earth ground/green or bare copper) through the upper left side housing knockout directly to the power supply terminal block as marked "HOT", "NEUTRAL" and "GROUND".

Note: The Earth Ground wire must always be first on and last off the terminal and secured by a separate nut). Ensure the 120VAC branch circuit breaker remains turned off before proceeding.

MAINTENANCE

The GEMC-12V2APS should be tested at least once a month for proper operation as follows:

Output Voltage Test: Under normal load conditions, the DC output voltage should be checked for proper voltage levels (12.1VDC nominal).

Battery Test: Under normal load conditions check that the battery is fully charged (approximately 13.5 to 13.8VDC). Check the voltage at the battery terminal and at the board terminal marked [-BAT +] to insure there is no break in the battery connection wires.

Note: Maximum charging rate is 1.5A. Expected battery life is approximately five years, however it is recommended changing batteries in four years or less if needed.

OVERCURRENT PROTECTION

The battery pairs are protected with two 3A overcurrent protection devices. If batteries are mis-wired, a battery trouble will be initiated (refer to **LED STATUS INDICATION TABLE**).

TERMINAL DESCRIPTIONS

1. (+) AUX 1
2. (-) AUX 1
3. (+) AUX 2

LED STATUS INDICATION TABLE (for inputs, outputs & trouble memory status)

LED NAME	OFF	ON
EZM STATUS	No Power	(Short Flash is "normal") Rapid flash indicates charging circuit trouble
BAT TBL	Normal	Low Battery, no battery or charging circuit trouble
AC ON	AC Loss (running on battery)	AC present (with or without battery power)
TBL	Normal	Low battery, no battery or charging circuit trouble, AC Loss (running on battery), tamper indication, microprocessor failure, or overcurrent on Aux 1 or Aux 2.
PWR	No Power	Power present
AUX 1	Normal	Output Overload
AUX 2	Normal	Output Overload

4. **(-) AUX 2**
Auxiliary power outputs rated 12VDC regulated, 2A maximum. Maximum combined alarm + standby current output is 2A.
5. **(-) NO AC**
Optional output: Active Low 2A Output. Normally active turns off when no AC or brownout is detected. Connect to power limited circuits only, 30VDC maximum.
6. **(-) BAT TBL**
Active Low 2A Output. Normally active turns off when no battery, low battery and/or battery charging circuit trouble is detected. Connect to power limited circuits only, 30VDC maximum.
7. **(-) TBL**
Active Low 2A Output. Normally active turns off when microprocessor stops functioning. Connect to power limited circuits only, 30VDC maximum.
8. **(+) REMOTE**
9. **(-) REMOTE**
10. **(-) REMOTE GRN**
11. **(+) REMOTE YEL**
Terminals 8-11 are not used in this configuration. Leave unconnected.
12. **(+) TAMPER**
Housing tamper positive terminal. Terminal 12 is not used in this configuration. If housing tamper is required, you must program and dedicate a control panel zone for this function, and wire the front and/or back tamper as required.

BURGLARY ALARM AUXILIARY POWER SUPPLY WIRING DIAGRAM

This wiring is for panels where the negative terminal of the zone is common to system ground. If the negative terminal of the zone is not common to system ground, then each trouble output requires a relay suitable for the application as shown on page 15.

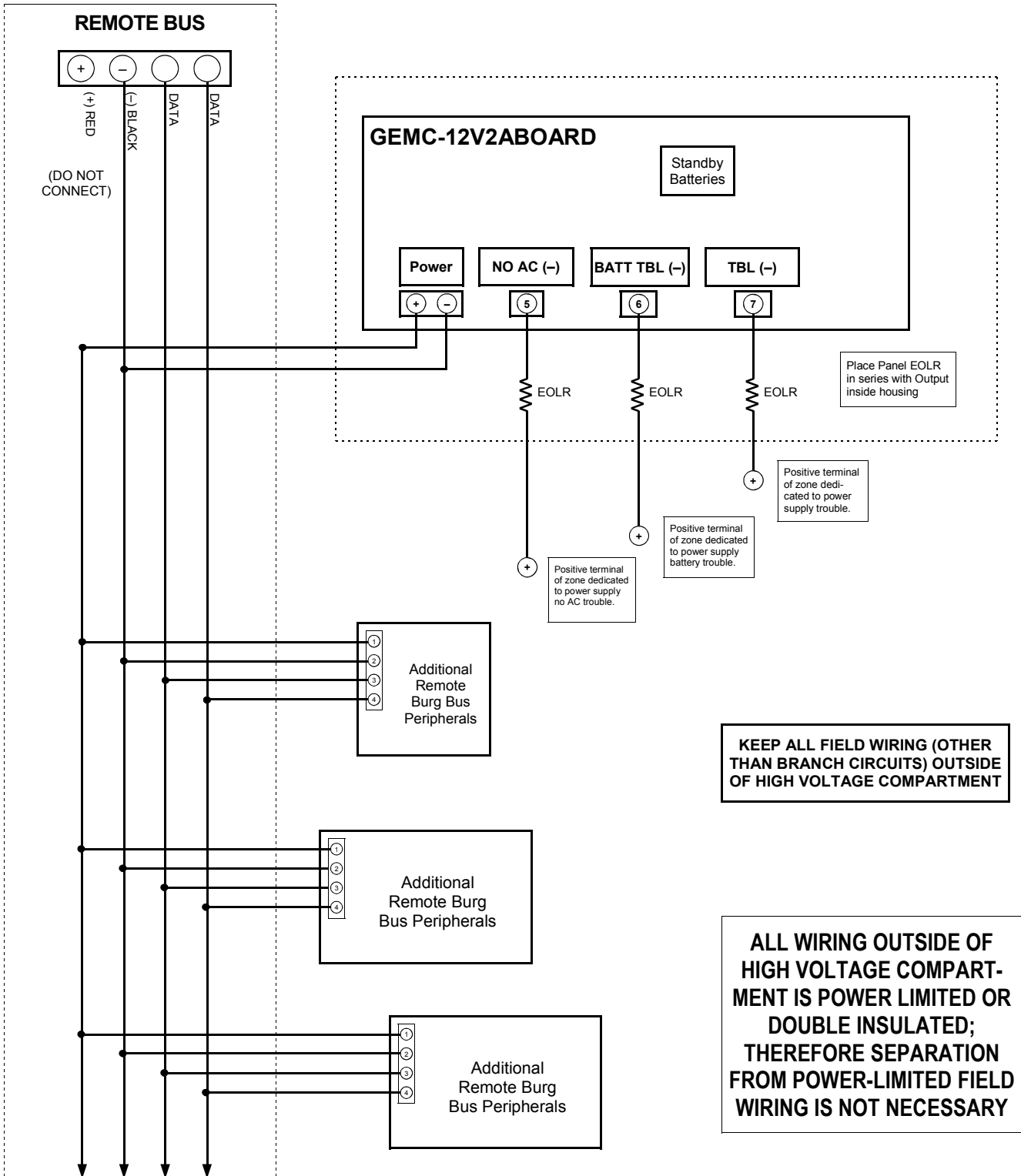

FIRE ALARM AUXILIARY POWER SUPPLY WIRING DIAGRAM

This wiring is for data panels where the negative terminal of the zone is not common to system ground. Each trouble output requires a relay suitable for the application as shown.

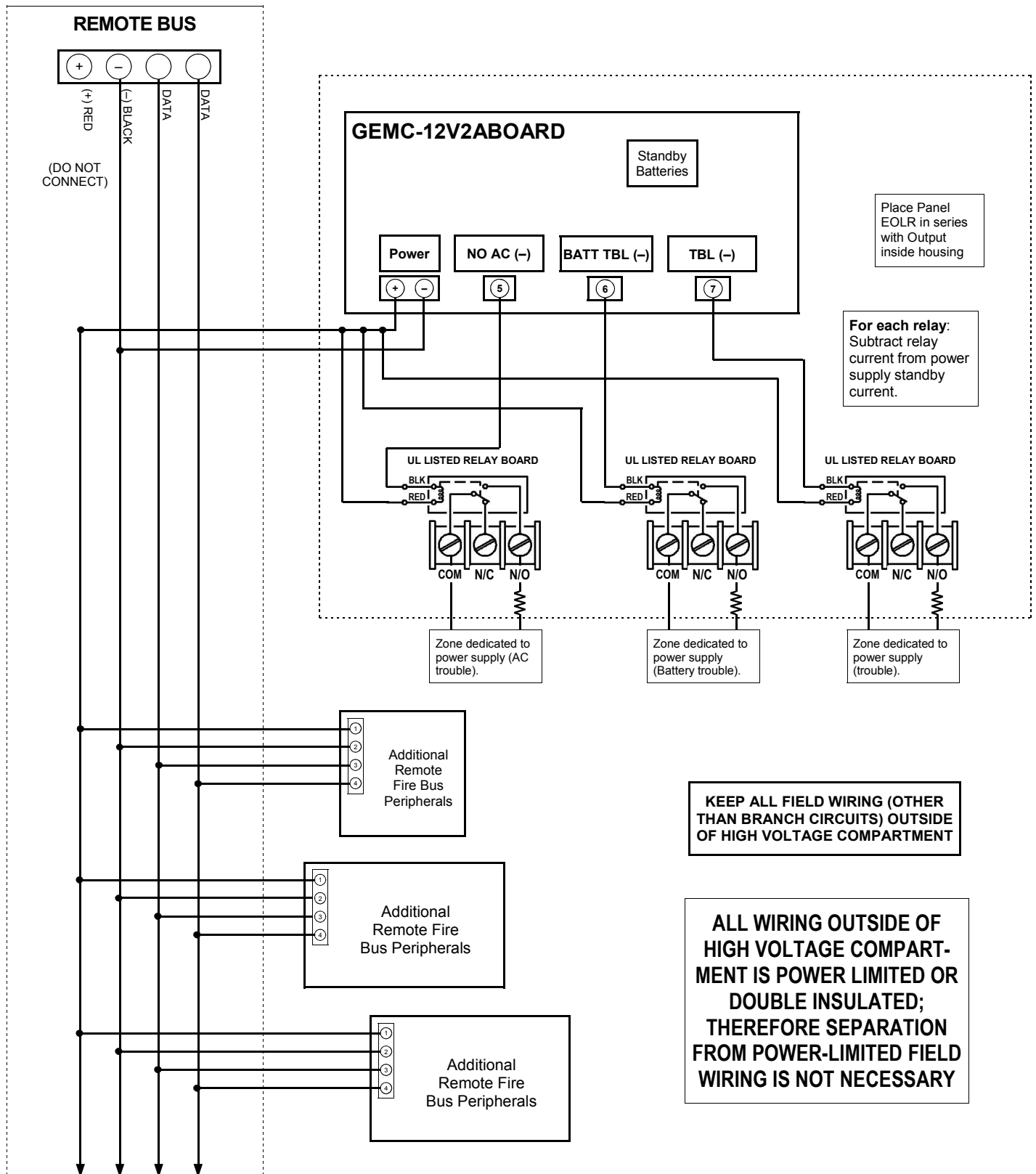

REGULATED POWER SUPPLY: GEMC-12V2APS-CF, GEMC-12V2APS-R & GEMC-12V2ABOARD WIRING DIAGRAM

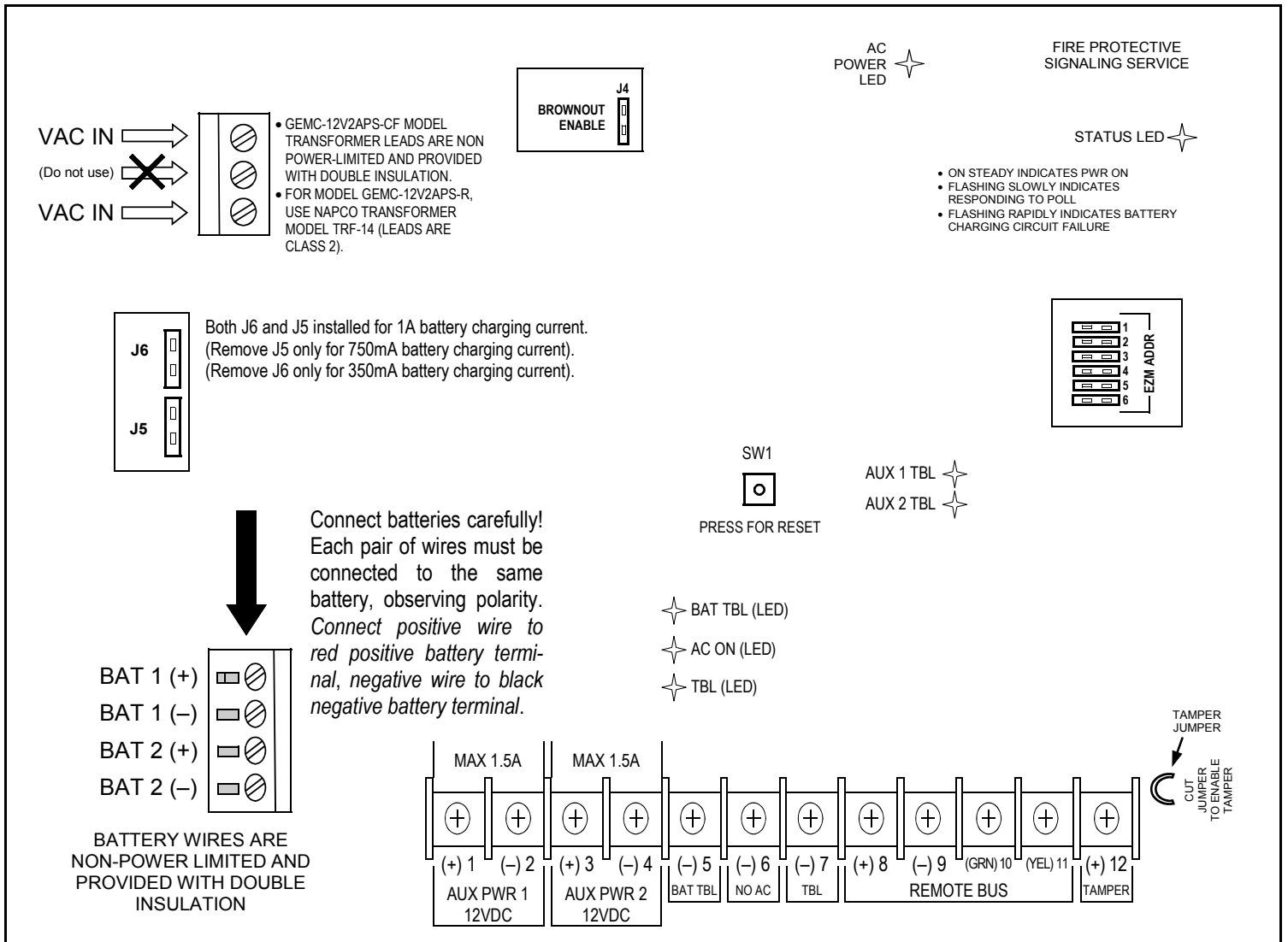

1. MAX COMBINED 12V REGULATED (MAX 0.5V RIPPLE) **AUX PWR** OUTPUT = 2 AMPS FOR -CF VERSION, 1.75A FOR -R VERSION (**LESS 40mA STANDBY CURRENT FOR POWER SUPPLY BOARD**).
2. INPUT RATED 120V, 1A, 60HZ FOR -CF VERSION; 120V, 60HZ, 60W FOR -R VERSION.
3. MAX 12V REGULATED (MAX 0.5V RIPPLE) **AUX PWR** OUTPUT FROM EITHER OUTPUT = 1.5 AMPS.
4. REFER TO W11828 FOR ADDITIONAL INSTALLATION INSTRUCTIONS AND STANDBY CURRENT BATTERY CHARTS.
5. **AUX PWR 1, AUX PWR 2, AND REMOTE BUS** WIRES ARE POWER LIMITED.
6. CONNECT **BAT TBL, NO AC** AND **TBL** TERMINALS ONLY TO POWER LIMITED SOURCES MAX 30V, 2A.
7. ROUTE POWER LIMITED WIRING OUTSIDE OF TRANSFORMER COMPARTMENT.
8. STANDBY CURRENT DETERMINED BY BATTERIES AND APPLICATION.
9. WIRE RANGE 14-22AWG. MAXIMUM TWO WIRES PER TERMINAL. EXCEPTION: ONE WIRE PER TERMINAL FOR BATTERY TERMINAL BLOCK AND "VAC IN" TERMINAL BLOCK.
10. INSTALL IN ACCORDANCE WITH NFPA 72 AND ALL LOCAL CODES.

GEMC-12V2APS-CF COMMERCIAL BURGLARY BATTERY / CURRENT SPECIFICATIONS

BATTERY CONFIGURATION	JUMPER SELECTION			MAXIMUM 4 HOUR 12V STANDBY CURRENT*	MAXIMUM 24 HOUR 12V STANDBY CURRENT*	MAXIMUM 12V STANDBY + ALARM CURRENT*
	SHUNT 5	SHUNT 6	RECHARGE CURRENT (mA)			
TWO 12V 4AH, 4.5AH, 5AH	ON	ON	1000	1.25A	0.250A	1.75A
TWO 12V 7AH, 7.5AH	ON	ON	1000	2A	0.500A	2A
TWO 12V 8AH	ON	ON	1000	2A	0.550A	2A
TWO 12V 12AH	ON	ON	1000	1.1A	0.850A	2A

GEMC-12V2APS-CF COMMERCIAL FIRE BATTERY / CURRENT SPECIFICATIONS

BATTERY CONFIGURATION	JUMPER SELECTION			MAXIMUM 24 HOUR 12V STANDBY CURRENT*	MAXIMUM 12V STANDBY + ALARM CURRENT*
	SHUNT 5	SHUNT 6	RECHARGE CURRENT (mA)		
TWO 12V 4AH, 4.5AH, 5AH	ON	ON	1000	0.250A	2A
TWO 12V 7AH, 7.5AH	ON	ON	1000	0.500A	2A
TWO 12V 8AH	ON	ON	1000	0.550A	2A
TWO 12V 12AH	ON	ON	1000	0.85A	2A

*Less 40mA standby current for power supply board
SEE W11828 FOR OTHER STANDBY AND ALARM RATINGS.

NOTES

NOTES

NOTES

NAPCO LIMITED WARRANTY

NAPCO SECURITY SYSTEMS, INC. (NAPCO) warrants its products to be free from manufacturing defects in materials and workmanship for *thirty-six months* following the date of manufacture. NAPCO will, within said period, at its option, repair or replace any product failing to operate correctly without charge to the original purchaser or user.

This warranty shall not apply to any equipment, or any part thereof, which has been repaired by others, improperly installed, improperly used, abused, altered, damaged, subjected to acts of God, or on which any serial numbers have been altered, defaced or removed. Seller will not be responsible for any dismantling or reinstallation charges.

THERE ARE NO WARRANTIES, EXPRESS OR IMPLIED, WHICH EXTEND BEYOND THE DESCRIPTION ON THE FACE HEREOF. THERE IS NO EXPRESS OR IMPLIED WARRANTY OF MERCHANTABILITY OR A WARRANTY OF FITNESS FOR A PARTICULAR PURPOSE. ADDITIONALLY, THIS WARRANTY IS IN LIEU OF ALL OTHER OBLIGATIONS OR LIABILITIES ON THE PART OF NAPCO.

Any action for breach of warranty, including but not limited to any implied warranty of merchantability, must be brought within the six months following the end of the warranty period. IN NO CASE SHALL NAPCO BE LIABLE TO ANYONE FOR ANY CONSEQUENTIAL OR INCIDENTAL DAMAGES FOR BREACH OF THIS OR ANY OTHER WARRANTY, EXPRESS OR IMPLIED, EVEN IF THE LOSS OR DAMAGE IS CAUSED BY THE SELLER'S OWN NEGLIGENCE OR FAULT.

In case of defect, contact the security professional who installed and maintains your security system. In order to exercise the warranty, the product must be returned by the security professional, shipping costs prepaid and insured to NAPCO. After repair or replacement, NAPCO assumes the cost of returning products under warranty. NAPCO shall have no obligation under this warranty, or otherwise, if the product has been repaired by others, improperly installed, improperly used, abused, altered, damaged, subjected to accident, nuisance, flood, fire or acts of God, or on which any serial numbers have been altered, defaced or removed. NAPCO will not be responsible for any dismantling, reassembly or reinstallation charges.

This warranty contains the entire warranty. It is the sole warranty and any prior agreements or representations, whether oral or written, are either merged herein or are expressly cancelled. NAPCO neither assumes, nor authorizes any other person purporting to act on its

behalf to modify, to change, or to assume for it, any other warranty or liability concerning its products.

In no event shall NAPCO be liable for an amount in excess of NAPCO's original selling price of the product, for any loss or damage, whether direct, indirect, incidental, consequential, or otherwise arising out of any failure of the product. Seller's warranty, as hereinabove set forth, shall not be enlarged, diminished or affected by and no obligation or liability shall arise or grow out of Seller's rendering of technical advice or service in connection with Buyer's order of the goods furnished hereunder.

NAPCO RECOMMENDS THAT THE ENTIRE SYSTEM BE COMPLETELY TESTED WEEKLY.

Warning: Despite frequent testing, and due to, but not limited to, any or all of the following; criminal tampering, electrical or communications disruption, it is possible for the system to fail to perform as expected. NAPCO does not represent that the product/system may not be compromised or circumvented; or that the product or system will prevent any personal injury or property loss by burglary, robbery, fire or otherwise; nor that the product or system will in all cases provide adequate warning or protection. A properly installed and maintained alarm may only reduce risk of burglary, robbery, fire or otherwise but it is not insurance or a guarantee that these events will not occur. CONSEQUENTLY, SELLER SHALL HAVE NO LIABILITY FOR ANY PERSONAL INJURY, PROPERTY DAMAGE, OR OTHER LOSS BASED ON A CLAIM THE PRODUCT FAILED TO GIVE WARNING. Therefore, the installer should in turn advise the consumer to take any and all precautions for his or her safety including, but not limited to, fleeing the premises and calling police or fire department, in order to mitigate the possibilities of harm and/or damage.

NAPCO is not an insurer of either the property or safety of the user's family or employees, and limits its liability for any loss or damage including incidental or consequential damages to NAPCO's original selling price of the product regardless of the cause of such loss or damage.

Some states do not allow limitations on how long an implied warranty lasts or do not allow the exclusion or limitation of incidental or consequential damages, or differentiate in their treatment of limitations of liability for ordinary or gross negligence, so the above limitations or exclusions may not apply to you. This Warranty gives you specific legal rights and you may also have other rights which vary from state to state.

IMPORTANT WIRING METHODS



For single-conductor terminal blocks (like the type shown at left), to terminate more than one conductor to a terminal, use the wiring methods shown at right:

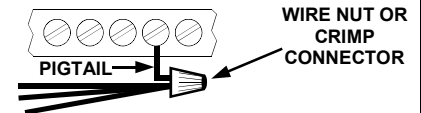
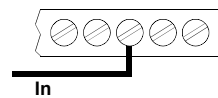
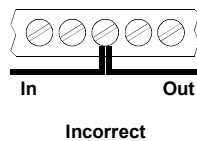

Correct -- Single incoming and/or pigtail with wire nut / crimp connectors



For "barrier" type terminal blocks (like the type shown at left), to terminate two conductors to a terminal, use the wiring methods shown at right:

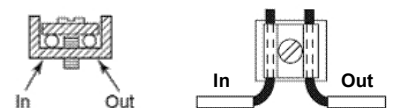
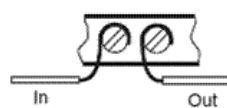
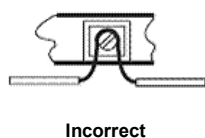

Correct -- Separate incoming and outgoing conductors

To terminate more than two conductors or conductors of different wire sizes to a terminal, use the "pigtail" type wiring method as shown at right. Use insulated wire for the pigtail, and firmly secure the conductors to the pigtail using an appropriate wire nut or crimp connector for the number and gauge of conductors used.

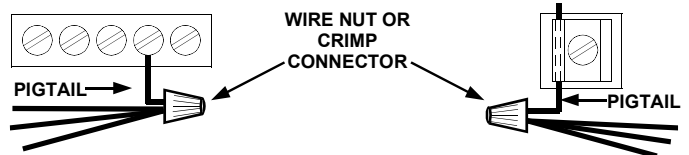
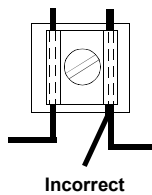

Correct -- Use pigtail and wire nut / crimp connector