



Product Description

The KBC **eCopper™** line of products offer a cost-effective way to connect the latest IP cameras using existing coax or copper (UTP) wiring to a remote monitoring station. In addition to saving costs and time from cabling infrastructure upgrades to CAT5/5e/6, **eCopper™** powers both its transmitter and remote cameras, eliminating the need for any additional power source at the camera site. **eCopper™** also extends the IP camera cable run distance from 100 to 300 meters, making it ideal for upgrading analog to IP cameras and other systems in large corporate buildings, retail, casinos, banks, prisons, stadiums and other applications.



The KBC EECF1-LN1-R-MN-B is a fully ruggedized Ethernet over coax one channel receiver. Its BNC port connects to coax and its 10/100M Base-T port connects to a switch. It provides connectivity to a single PoC/PoE device EECF1-LS1-T-MN-B transmitter. Power is supplied to the transmitter through the coaxial cable. Varying data rates are supported depending on cable distance and quality. Plug-and-play design ensures ease of installation with no electrical adjustment needed. LED indicators are provided to show the operational status of the unit. This one channel receiver is installed with a metal clip.

Product Features

- 1 coax ports with PoC
- 1 *10/100 Base-T port
- Connect to 1 unit EECF1-LS1-T-IN-B or 1 unit EECF1-LS1-T-MN-B
- Coax data rate >50Mbps (300m)
- PoE+ is supported up to 300m based on coax quality and applied voltage to coax (48~57VDC)
- Over current and short circuit protection
- Unique PoC transmission protection design so that no power is output when transmitter end is not connected

Typical System Configuration

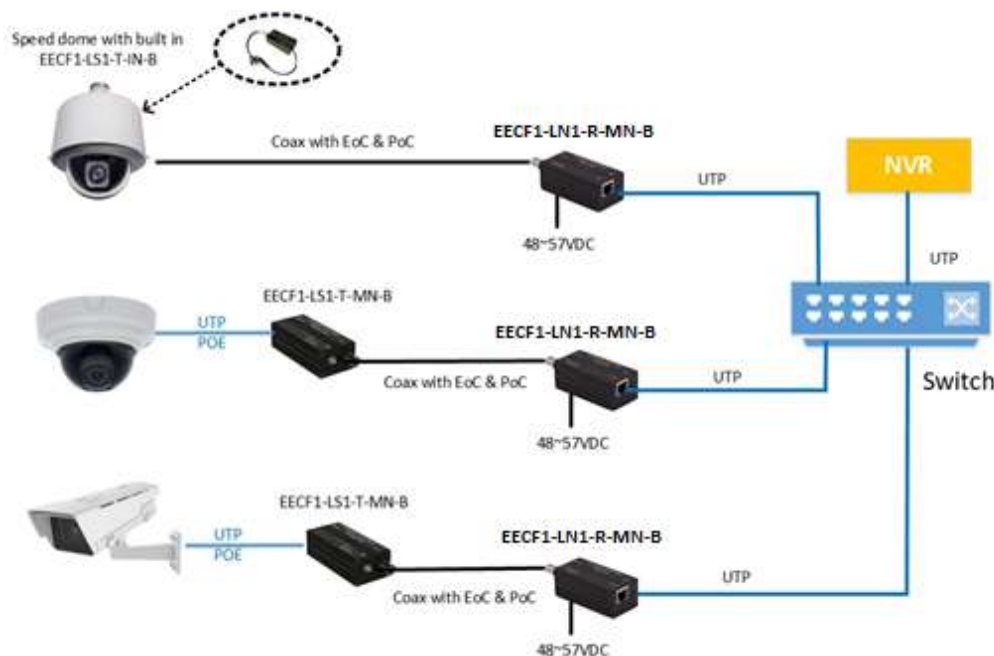

Specifications

Standards

IEEE Standard	IEEE 802.3 10BASE-T IEEE 802.3u 100BASE-TX IEEE 802.3x Full Duplex
---------------	--

Power⁽³⁾

Power Input	48~57VDC
Power Consumption	≤1W (Without PoC)

LAN Port

Data Rate	10/100Mbps auto-sensing Half & full duplex
-----------	---

Environmental

Operating Temperature	-20° ~ +70°C
Storage Temperature	-40° ~ +85°C
Operating Humidity	0 to 95% non-condensing
Mean Time Between Failure (MTBF)	> 100,000 Hours

Coax Port

Cable	Coaxial Cable (75Ω)
Data Rate ⁽¹⁾	>50Mbps (300m)
Maximum PoE Distance ⁽²⁾	700m
Maximum PoE+ Distance ⁽²⁾	300m

Connectors

Ethernet	RJ45
Coax	BNC
Power	Screw Block Terminal

Dimension

L x W x H	76mm X 37mm X 29mm
-----------	--------------------

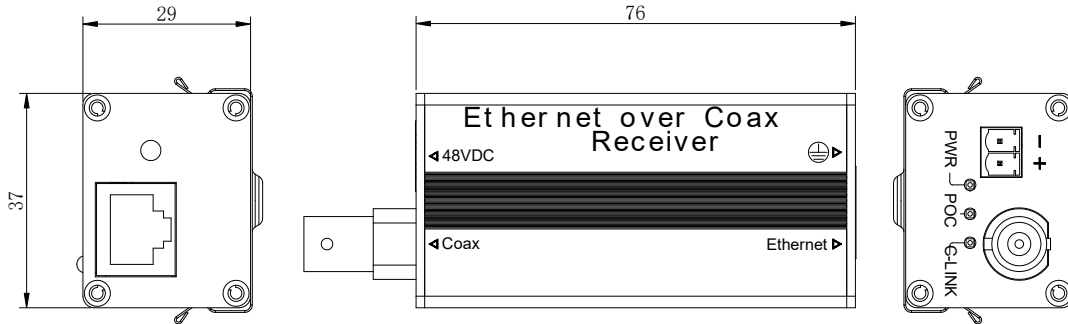

Part Number

EECF1-LN1-R-MN-B

- (1) The data is based on RG59 and is related to coax quality
- (2) The data is based on the RG59 test and is related to coax quality and applied voltage(48~57VDC) to coax.
- (3) Power Supply sold separately; suggested Power supply is KBC NDR-75-48, GST60A48

Due to ongoing technological improvements, product specifications are subject to change without notice. KBC is not liable for any errors, omissions or changes of any description of the goods contained herein. This information is for the sole purpose of identifying the products and KBC makes no warranty that the products conform to any description contained herein. Do not rely solely on any representations, statements, or assertions concerning these Products contained herein.